



OPENBUILDS®

Multi-Z Add-On for LEAD CNC Machine 1515

Assembly Guide: Triple Z

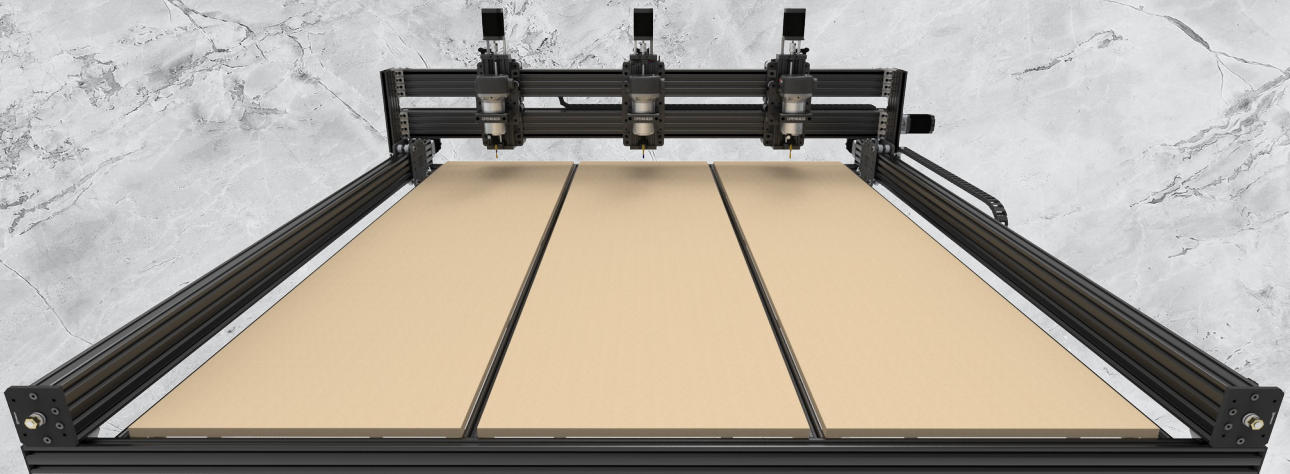

Table of Contents

1. Introduction.....	4
2. Prepare your LEAD CNC Machine 1515.....	4
2.1 Park Y axis (gantry) and X axis (carriage) at center of each axis.....	4
2.2 Power off the machine.....	4
3. Prepare Sub-Assemblies.....	5
3.1 Pre-assemble V-Wheel Kits.....	5
3.2 Prepare Additional X-Carriage Assembly / Assemblies.....	6
3.2.1 Assemble the Eccentric side V-Wheel stack.....	7
3.2.2 Assemble the Fixed side V-Wheel stack.....	8
3.2.3 Assemble Double XL Gantry Plate Stack.....	9
3.2.4 Completed Double XL Gantry Plate Stack.....	9
3.3 Prepare Additional Z Axis Actuator Assembly / Assemblies.....	10
3.3.1 Assemble the Z Axis Carriage: Install V-Wheels.....	10
3.3.2 Assemble the Z Axis Carriage: Install Anti-Backlash Nut Block.....	11
3.3.3 Assemble the Z Axis Carriage: Install Router Mount.....	12
3.3.4 Assemble the Z Axis Carriage: Install Corner Connectors.....	13
3.3.5 Assemble the Z Axis Carriage: Install the Lead Screw into the Anti-Backlash Nut Block.....	14
3.3.6 Assemble the Z Axis Actuator: Install Corner Connectors.....	15
3.3.7 Assemble the Z Axis Actuator: Install Carriage.....	16
3.3.8 Assemble the Z Axis Actuator: Install C-Beam End Mounts.....	17
3.3.9 Assemble the Z Axis Actuator: Install Stepper Motor.....	18
3.3.10 Assemble the Z Axis: Install Actuator onto X Carriages.....	19
3.3.11 Assemble the Z Axis: Pre-assemble Backbone.....	21
3.3.12 Assemble the Z Axis: Install Backbone.....	22
3.3.13 Actuator Assembly Complete.....	22
3.4 Prepare Gantry Locking Beam - Triple-Z.....	23
3.4.1 Install the Corner Brackets.....	23
3.4.2 Install the Double End Caps.....	24
3.4.3 Install the Drop In Tee Nuts.....	25
4. Partially Disassemble your LEAD CNC Machine 1515.....	26
4.1 Remove X-Axis C-Beam end assemblies.....	26
4.1.1 Left side (Triple-Z Only).....	26
4.1.2 Right side.....	27
4.2 Remove the X Axis Drag Chain.....	28
4.2.1 Remove the Drag Chain carrier.....	28
4.2.2 Remove the X-Axis Xtension Limit Switch (Triple-Z Only).....	30
5. Install the new Z Axis assemblies.....	31
5.1 Install the Left Side Z Axis (Triple-Z Only).....	31
5.1.1 Disconnect the two gantry beams from the left side upright.....	31
5.1.2 Loosen the C-Beam Linear Rail from the rear Cast Corners on the left.....	32
5.1.3 Move the Left side Upright forward.....	33
5.1.4 Remove the (3) Tee Nuts.....	34
5.1.5 Slide in the new left side Z axis Assembly.....	35
5.1.6 Move the Left side Upright back and re-attach.....	36
5.2 Install the Right Side Z Axis.....	37
5.2.1 Disconnect the two gantry beams from the right side upright.....	37
5.2.2 Loosen the C-Beam Linear Rail from the rear Cast Corners on the left.....	38

5.2.3 Move the Right side Upright forward.....	39
5.2.4 Remove the (3 Tee Nuts).....	40
5.2.5 Slide in the new right side Z axis Assembly.....	41
5.2.6 Move the Left side Upright back, and re-attach.....	42
5.3 Install Gantry Locking Beam.....	43
5.3.1 Install the Gantry Locking Beam onto the Z-Axis assemblies.....	43
5.4 Reassemble Xtension Limit Swtiches and Drag Chain.....	44
5.4.1 Reinstall the X axis Xtension Limit Switch.....	44
5.4.2 Reinstall the Drag Chain spacers.....	45
5.4.3 Reinstall the Drag Chain carrier and Drag Chain.....	46
5.4.4 Reinstall the left side C-Beam End Mounts.....	47
5.4.5 Reinstall the right side C-Beam End Mounts and motor.....	47
5.4.6 Re-tension the Lead Screw.....	48
6. Wiring.....	49
6.1 Wire additional Z-axis motors.....	49
6.1.1 Disassemble Z axis Backbone End caps.....	49
6.1.2 Install Flex Tubing Clamps on center Z-axis Backbone.....	50
6.1.3 Install Flex Tubing Clamps on Additional Z-axis Backbones.....	51
6.1.4 Install flex tubing.....	52
6.1.5 Install Terminal Block.....	53
6.1.6 Wire the Terminal Block junction.....	54
.....	54
6.1.7 Wire the Stepper Motors.....	55
6.1.8 Reinstall Endcaps.....	56
6.2 Install Routers.....	58
7. Calibration.....	59
7.1 Calibrating Router Height.....	59
7.1 Calibrating Relative Endmill Height.....	59
8. Assembly Complete!.....	60

1. Introduction

This Assembly Guide will help you install your Multi-Z Upgrade kit onto an OpenBuilds LEAD 1515 CNC machine.

2. Prepare your LEAD CNC Machine 1515

This guide assumes you have already built your LEAD CNC Machine 1515. If not, follow the Build Videos on <https://openbuilds.com/builds/openbuilds-lead-cnc-machine-1515-60-x-60.9552/> to perform the initial assembly and commissioning of your machine. Once it has been properly set up and working, it is easier to install the upgrade components onto the already known-working machine.

2.1 Park Y axis (gantry) and X axis (carriage) at center of each axis

Jog your machine so that the Gantry and X Axis are both at the center of travel. This will ease access to the components we will be working on during the following steps.

Also, ensure you have working access to both sides of the machine as you will be accessing both ends of the gantry in steps that follow. Remove any obstructions that may prevent you from working comfortably.

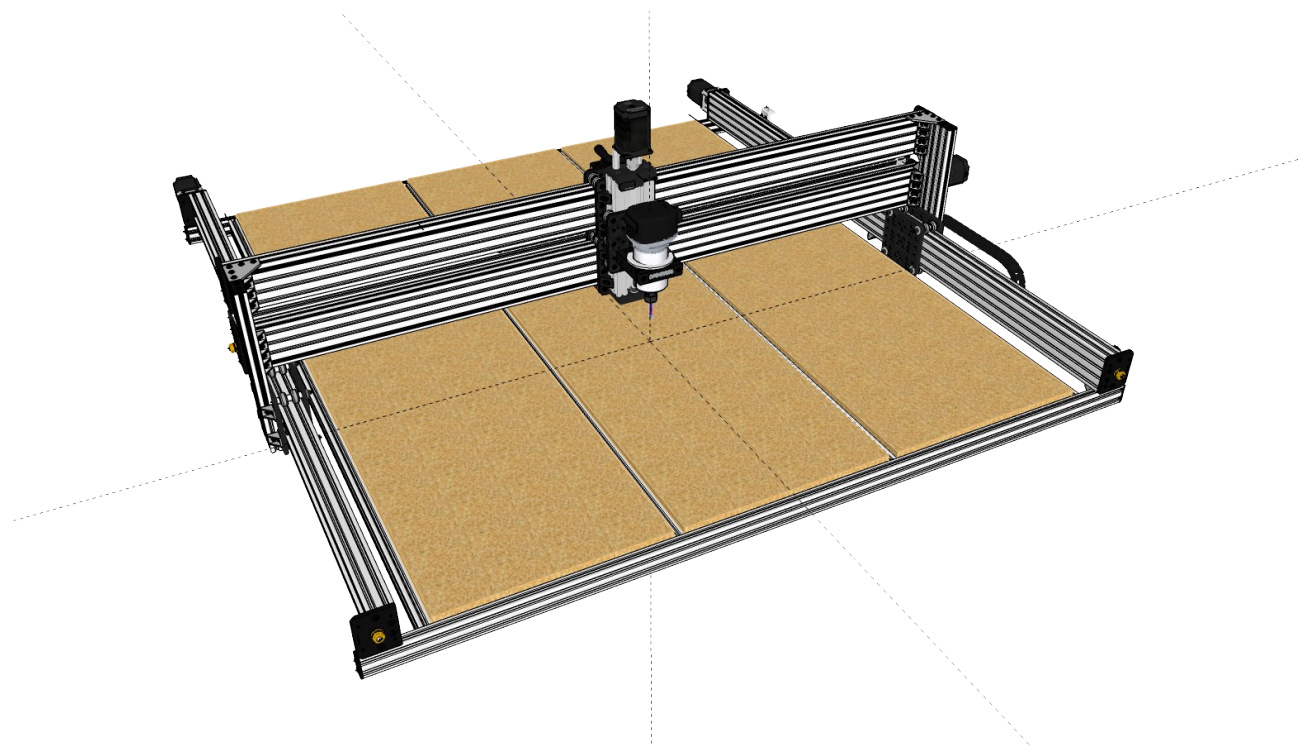

Figure 1: Position the machine at the center of the X and Y axis travel respectively

2.2 Power off the machine

Unplug the Router, Power supply and USB cable to prevent any possibility of damage. Never perform any work on the machine, and in particular on wiring, with any power to the machine.

3. Prepare Sub-Assemblies

3.1 Pre-assemble V-Wheel Kits

Included in your Multi-Z Upgrade kit are V-Wheel kits. Proceed to pre-assemble them using the standard assembly method you used to assemble the V-Wheels for your LEAD CNC Machine 1515. If you would like a video to guide you through V-Wheel assembly, check out <https://www.youtube.com/watch?v=YtkGiLg2edk>

- Insert one bearing into the V-Wheel and flip it over
- Place the Precision shim inside the wheel
- Insert the second bearing – making sure the Precision Shim is between the bearings
- Firmly seat both bearings

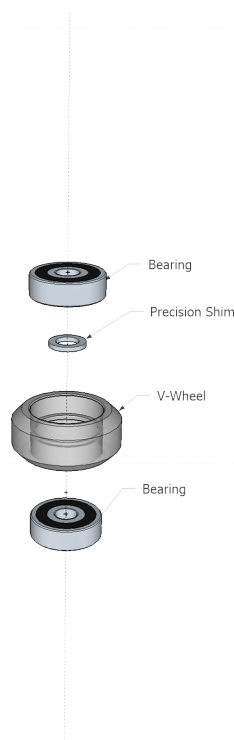

Figure 2: V-Wheel Assembly: Exploded View

3.2 Prepare Additional X-Carriage Assembly / Assemblies

- Triple-Z: Assemble 4x X-Carriage Assemblies: Follow Step 3.2 four times

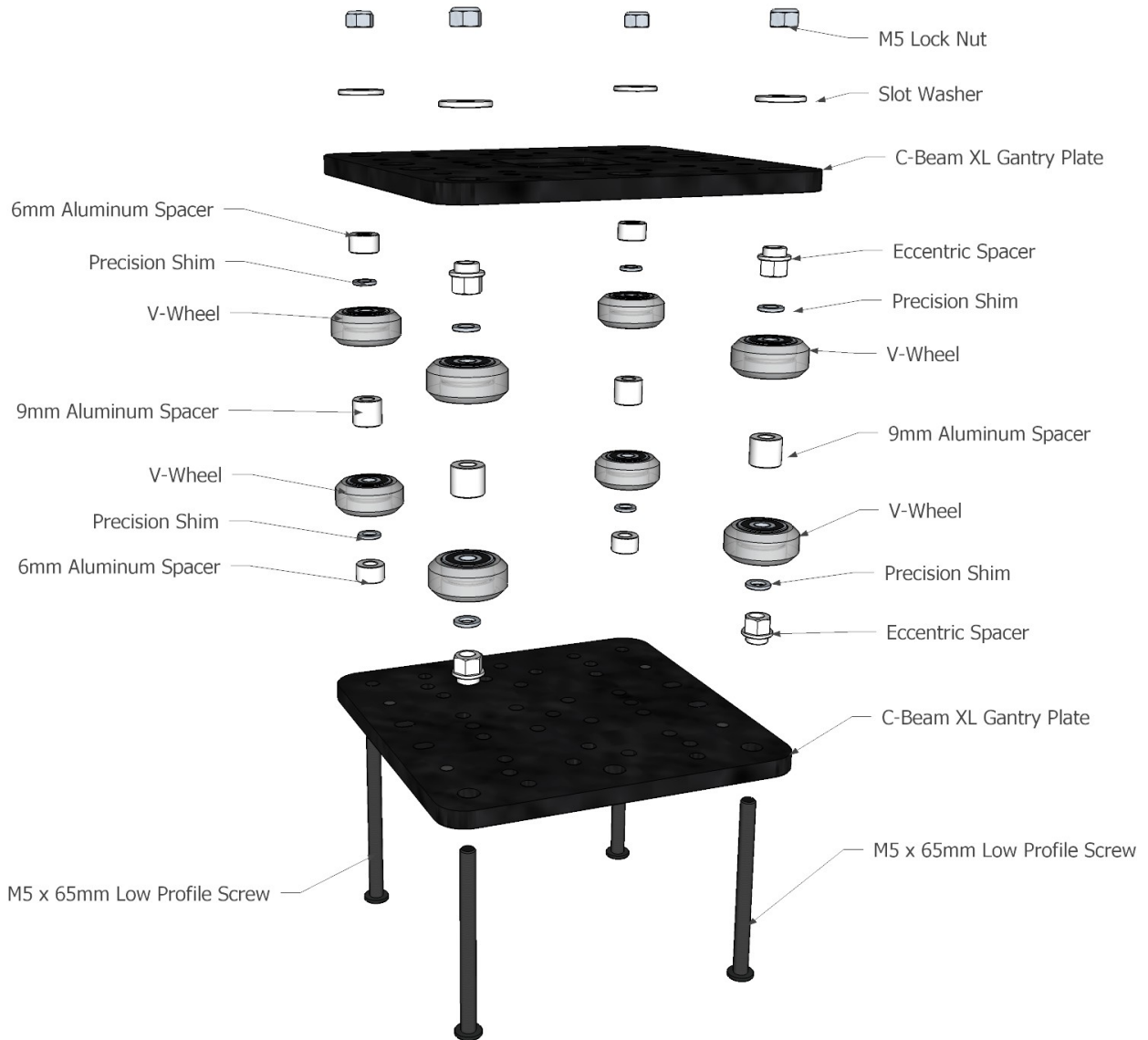

Figure 3: X-Axis Gantry Plate Assembly: Exploded View

If you'd like video guidance on this step: See https://www.youtube.com/watch?v=gWsdWk9W_zQ from around the 6 min 10 sec mark. Note: these assemblies do NOT make use of Nut Blocks so if you do follow the video ignore the sections discussing Nut Block installation.

3.2.1 Assemble the Eccentric side V-Wheel stack

Insert (2) M5 x 65mm Low Profile Screws through the larger (eccentric side) holes in the C-Beam XL Gantry plate. Onto these screws, place, in order:

- 6mm Eccentric Spacer
- Precision Shim
- V-Wheel
- 9mm Aluminum Spacer
- V-Wheel
- Precision Shim
- 6mm Eccentric Spacer

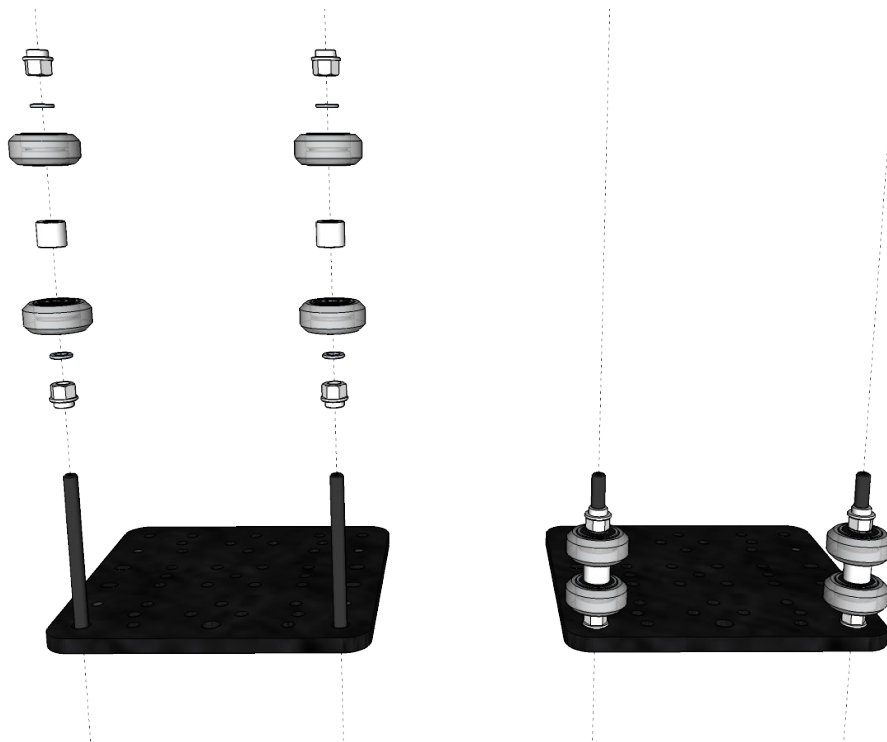

Figure 4: X-Carriage Assembly: Eccentric Side stack up



- Make sure the marker on the Eccentric spacers are facing outward, to allow for easier adjustment later
- You can use a permanent marker to color the marker face ensuring its more visible when you perform eccentric adjustments later

3.2.2 Assemble the Fixed side V-Wheel stack

Insert (2) M5 x 65mm Low Profile Screws through the smaller (fixed side) holes in the C-Beam XL Gantry plate. Onto these screws, place, in order:

- 6mm Aluminum Spacer
- Precision Shim
- V-Wheel
- 9mm Aluminum Spacer
- V-Wheel
- Precision Shim
- 6mm Aluminum Spacer

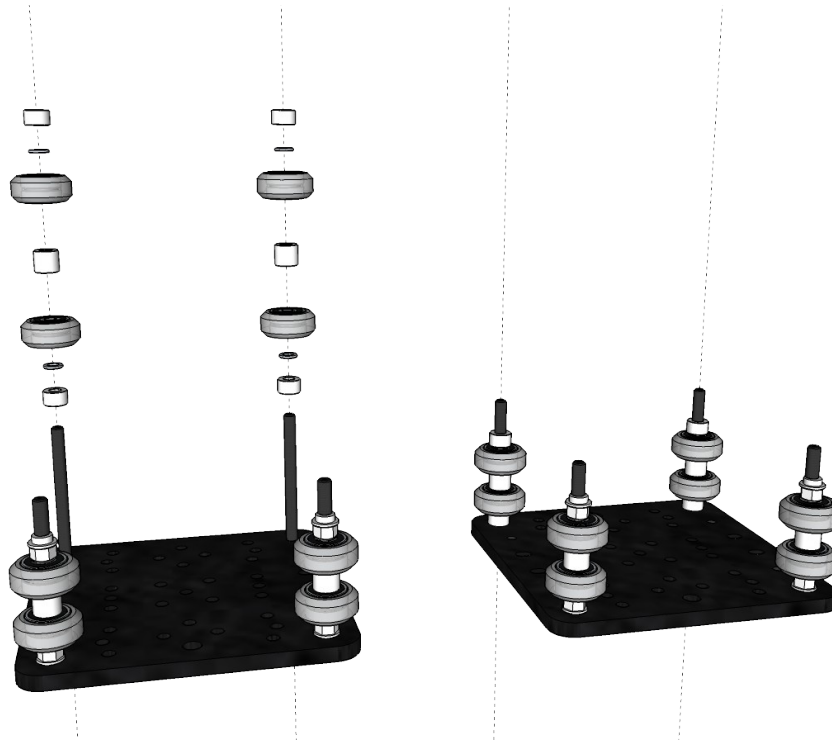

Figure 5: X-Carriage Assembly: Fixed Side stack up

3.2.3 Assemble Double XL Gantry Plate Stack

Install the second C-Beam XL Gantry plate on top, followed by (4) M5 Slot Washers and (4) M5 Nylon Insert Hex Locknuts as shown:

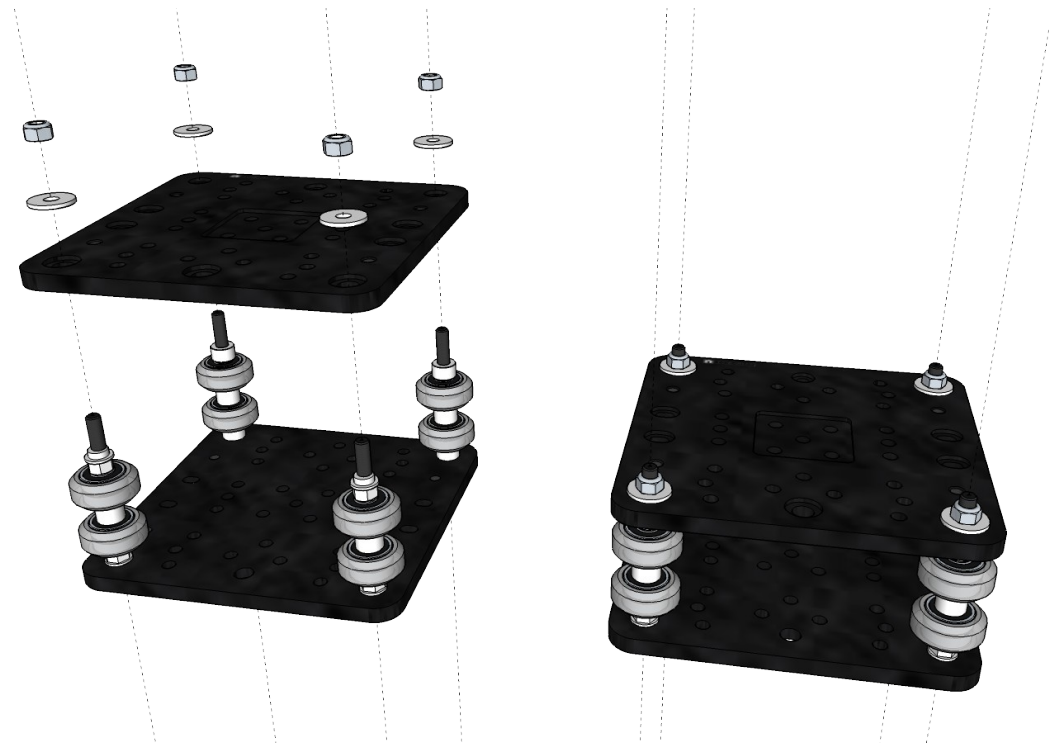

Figure 6: X-Carriage Assembly: Install Second Gantry Plate

3.2.4 Completed Double XL Gantry Plate Stack

Repeat steps 3.2.1 – 3.2.4 four times for a total of 4 assemblies

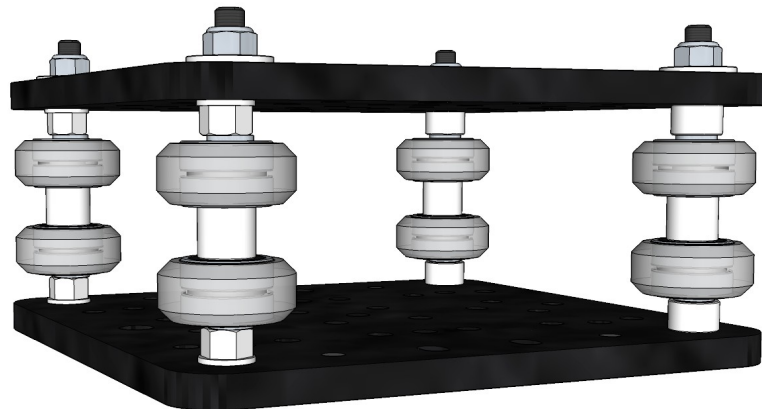

Figure 7: Completed Double XL Gantry Plate Stack

3.3 Prepare Additional Z Axis Actuator Assembly / Assemblies

3.3.1 Assemble the Z Axis Carriage: Install V-Wheels

Install the V-Wheels onto the C-Beam XL Gantry plate as shown:

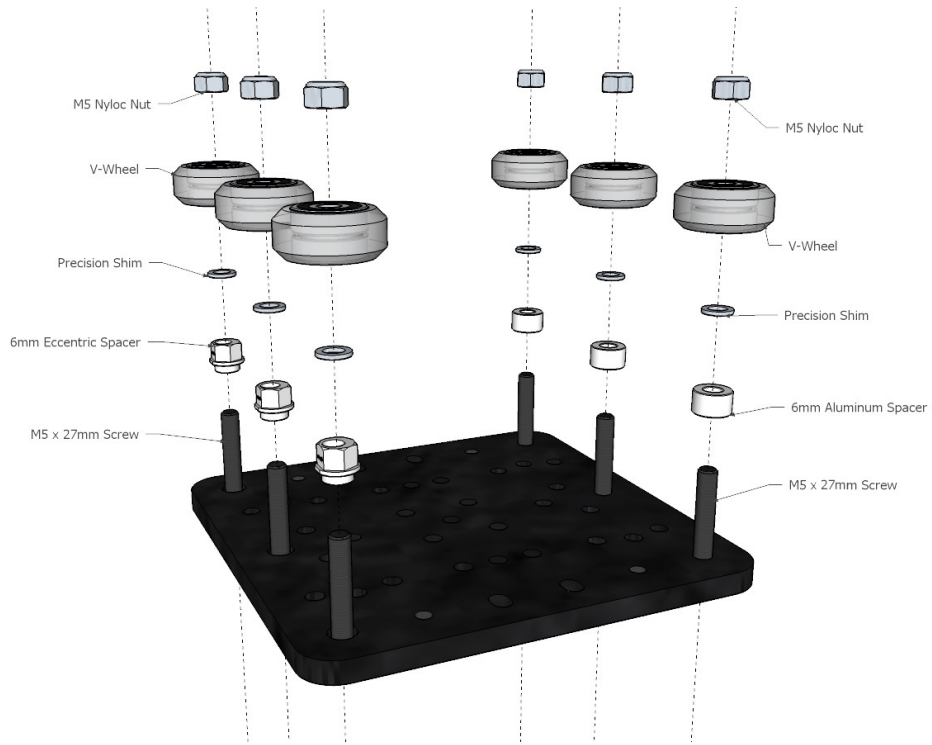

Figure 8: Assemble Z Axis Gantry Plate: Install V-Wheels: Exploded View

3.3.2 Assemble the Z Axis Carriage: Install Anti-Backlash Nut Block

Install the Anti-Backlash Nut Block onto the C-Beam XL Gantry Plate as shown

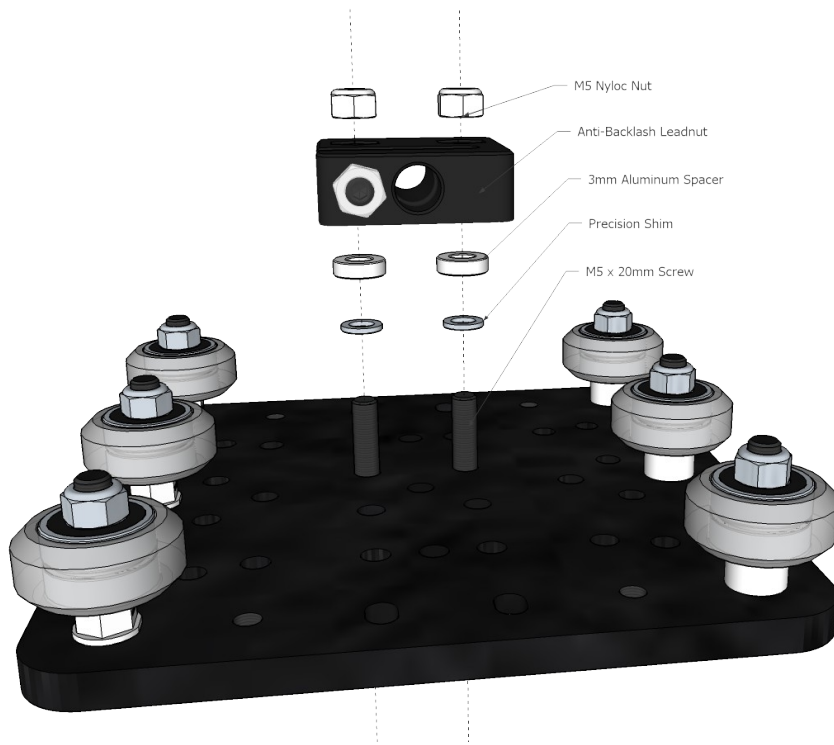

Figure 9: Assemble Z Axis Gantry Plate: Install Anti-Backlash Lead Nut: Exploded View

3.3.3 Assemble the Z Axis Carriage: Install Router Mount

Install the Router Mount using M5 x 10mm Low Profile screws as shown:



Figure 10: Assemble Z Axis Gantry Plate: Install Router Mount

3.3.4 Assemble the Z Axis Carriage: Install Corner Connectors

Install 2x Black Corner Connectors as show, using (4) M5 x 8mm Low Profile Screws to brace the Router Mount.



Figure 11: Assemble Z Axis Gantry Plate: Install Corner Connectors

3.3.5 Assemble the Z Axis Carriage: Install the Lead Screw into the Anti-Backlash Nut Block

Insert the Lead Screw into the Anti-Backlash Nut Block and adjust it to dial out any backlash. Then tighten the Lock Nut on the Set Screw to keep it locked in place.

If you'd like more information on adjusting the Anti-Backlash Nut Block, see our video <https://www.youtube.com/watch?v=LOi-Ig6GfyA>

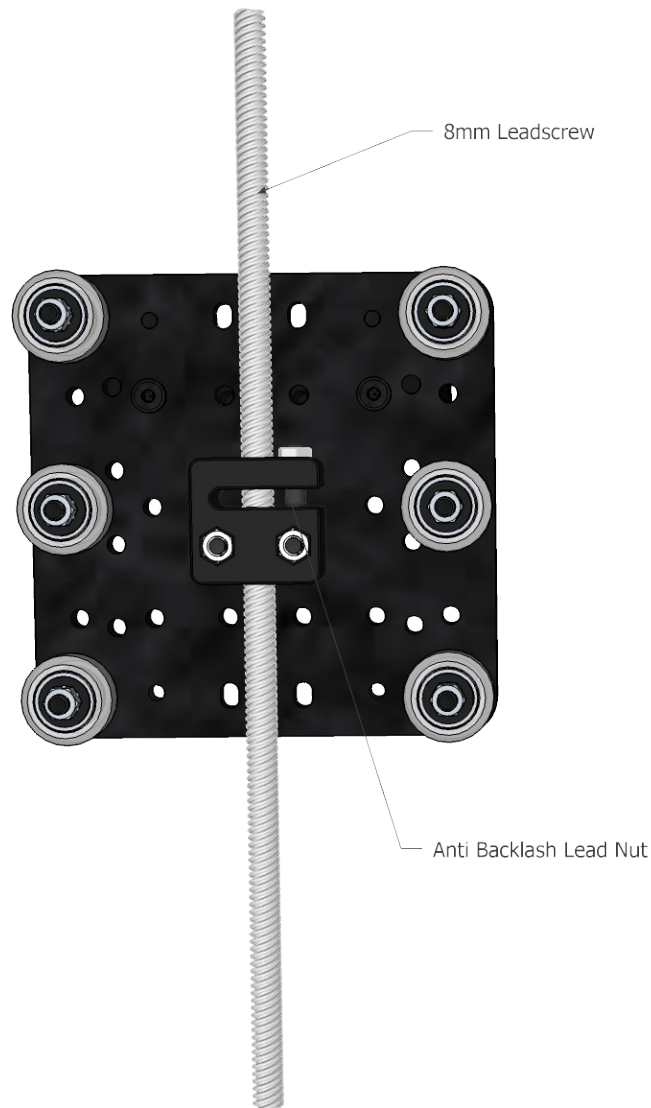

Figure 12: Assemble Z Axis Gantry Plate: Install Lead Screw

3.3.6 Assemble the Z Axis Actuator: Install Corner Connectors

Take the C-Beam Linear Rail and insert (4) Tee Nuts on one side in the rearward slot and repeat the same steps on the other side for a total of (8) Tee Nuts per C-Beam Linear Rail, as shown:

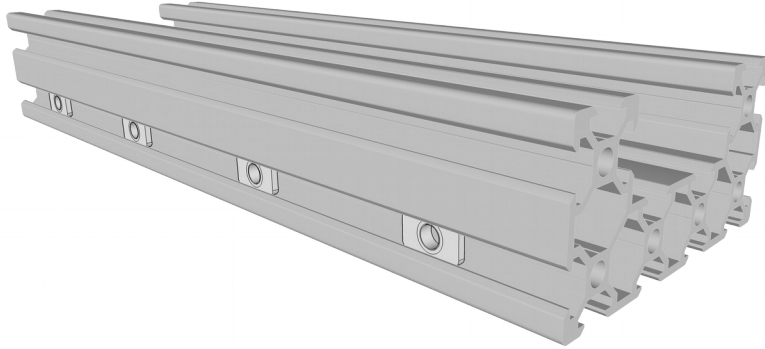

Figure 13: Assemble the Z Axis Actuator: Insert Tee Nuts

Then, loosely install (4) Black Angle Corner Connectors on one side and repeat the same step for the other side (for a total of (8) Corner Connectors per C-Beam Linear Rail) using (8) M5 x 8mm Low Profile Screws into the Tee Nuts, as shown. Leaving them a little loose will help them slide around to align them during later assembly steps.

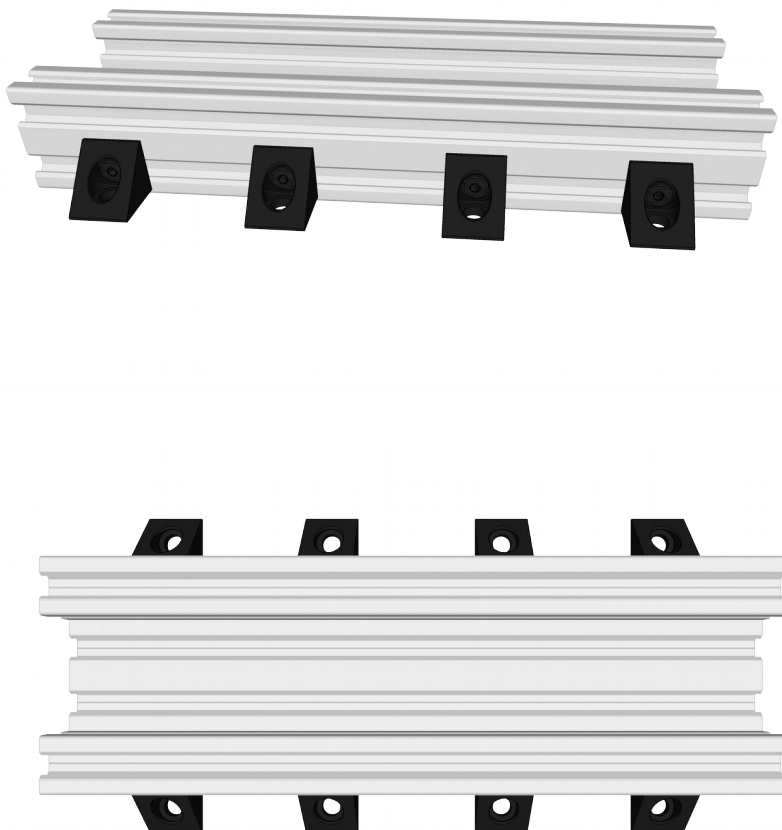

Figure 14: Assemble the Z Axis Actuator: Install Corner Connectors

3.3.7 Assemble the Z Axis Actuator: Install Carriage

Slide on the pre-assembly Carriage onto the C-Beam Linear Rail.

Also, install the Lock Collars, 8mm Shims, and Ball Bearings loosely onto the Lead Screw as they need to be in place before installing the C-Beam End Mounts in the next step.

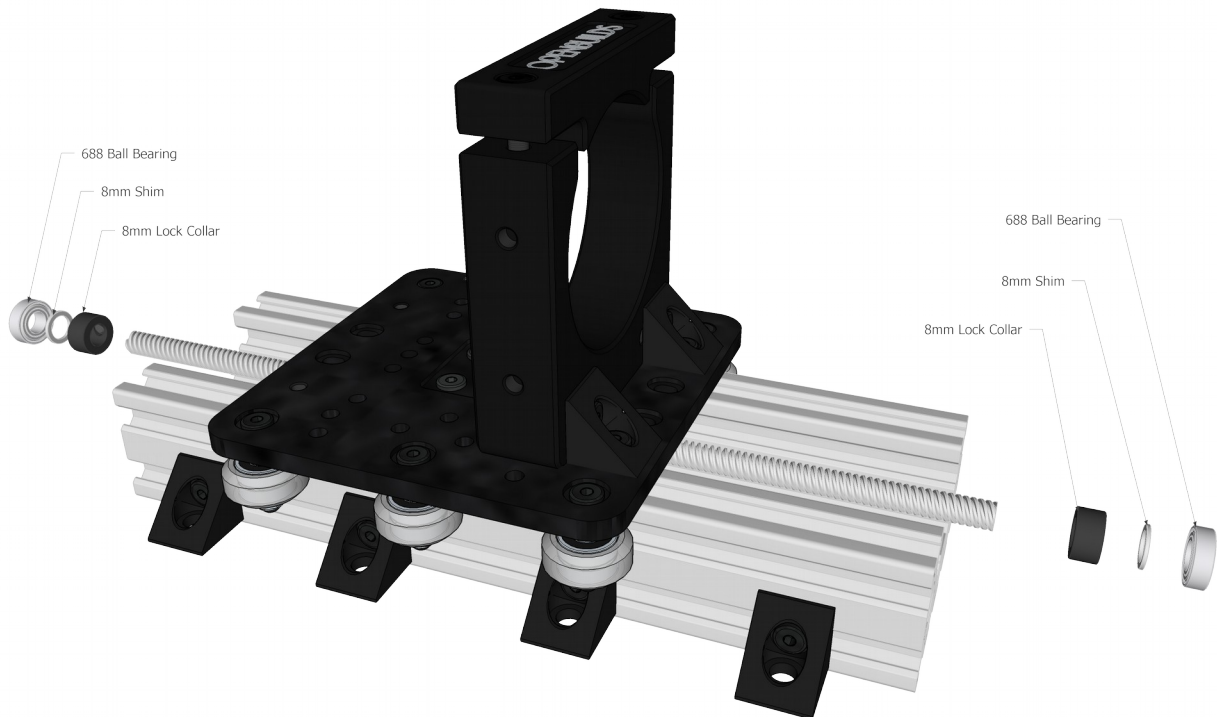

Figure 15: Install Z Carriage, Lock Collars, 8mm Shims and Ball Bearings

3.3.8 Assemble the Z Axis Actuator: Install C-Beam End Mounts

Install the two C-Beam End Mounts using (8) M5 x 20mm Low Profile Screws, as shown.

Once the C-Beam End Mounts are in place, also proceed to lock and constrain the Lead Screw just as you've done when assembling the LEAD CNC Machine 1515's original Z axis. Leave the remaining Lead Screw coming out of the top plate to later to attach the Flexible Coupling and motor.



Figure 16: Assemble the Z Axis Actuator: Install C-Beam End Mounts

3.3.9 Assemble the Z Axis Actuator: Install Stepper Motor

Install the NEMA 23 Stepper Motor using (2) 40mm Aluminum Spacers and (2) M5 x 55mm Low Profile Screws, as shown:

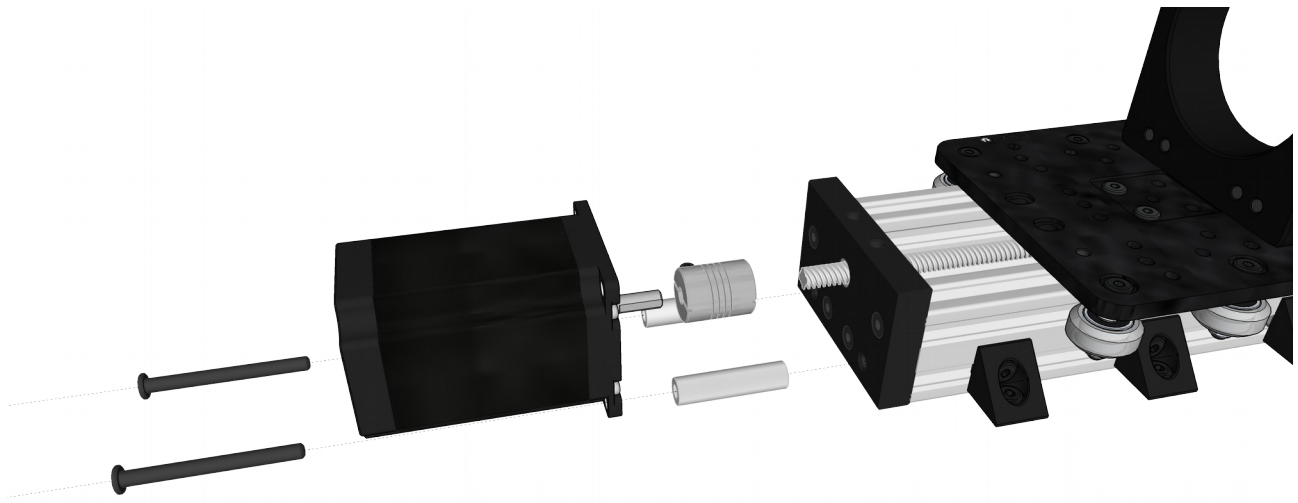

Figure 17: Assemble the Z Axis Actuator: Install the Stepper Motor

3.3.10 Assemble the Z Axis: Install Actuator onto X Carriages

Install the pre-assembled Z-Axis Actuator onto two X-Axis carriages using (8) M5 x 8mm Low Profile Screws, as shown. Take care to align the carriages correctly with Eccentric Spacers facing the bottom on both.



- Rotate the Lead Screw (but easier to hold onto the Flexible Coupling) moving the carriage up and down as it's in the way of some of the M5 Low Profile Screws that you will need to access. Moving the carriage up and down by turning the Lead Screw makes access to reach those screws.
- Remember to tighten the screws holding the Corner Connectors to the C-Beam Linear Rail as well as they were left loose in step 3.3.6 to allow aligning them to the tapped screw holes.

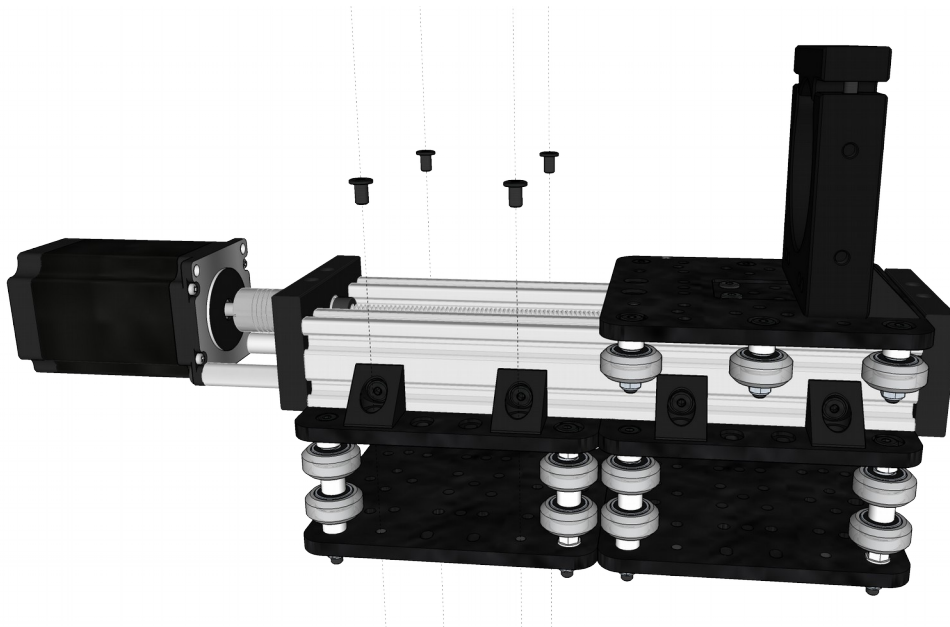

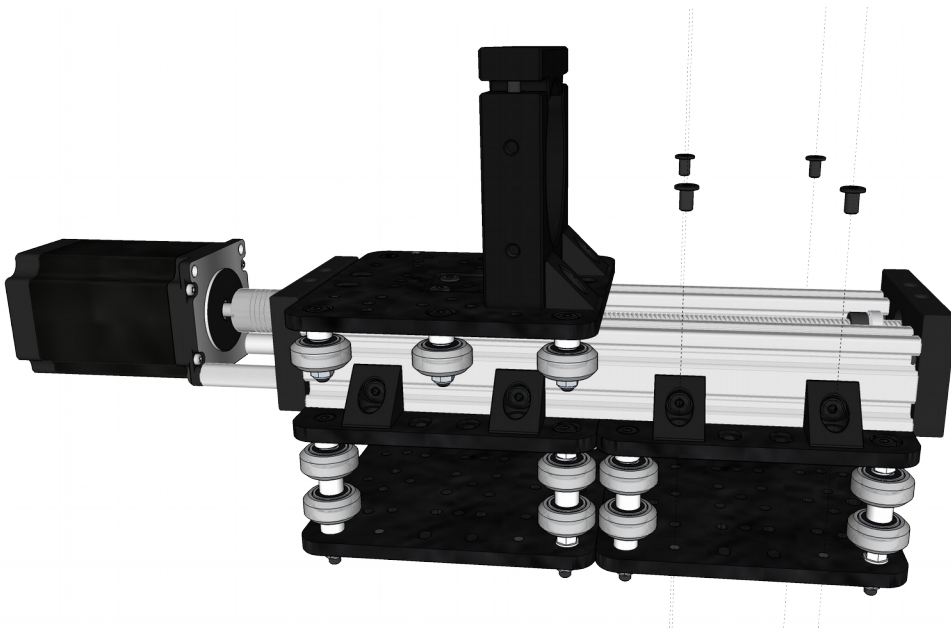

3.3.11 Assemble the Z Axis: Pre-assemble Backbone

Install (8) Cast Corners onto the 20x80 V-Slot Linear Rail using (8) M5 x 8mm Low Profile Screws and (8) M5 Tee Nuts, as shown:

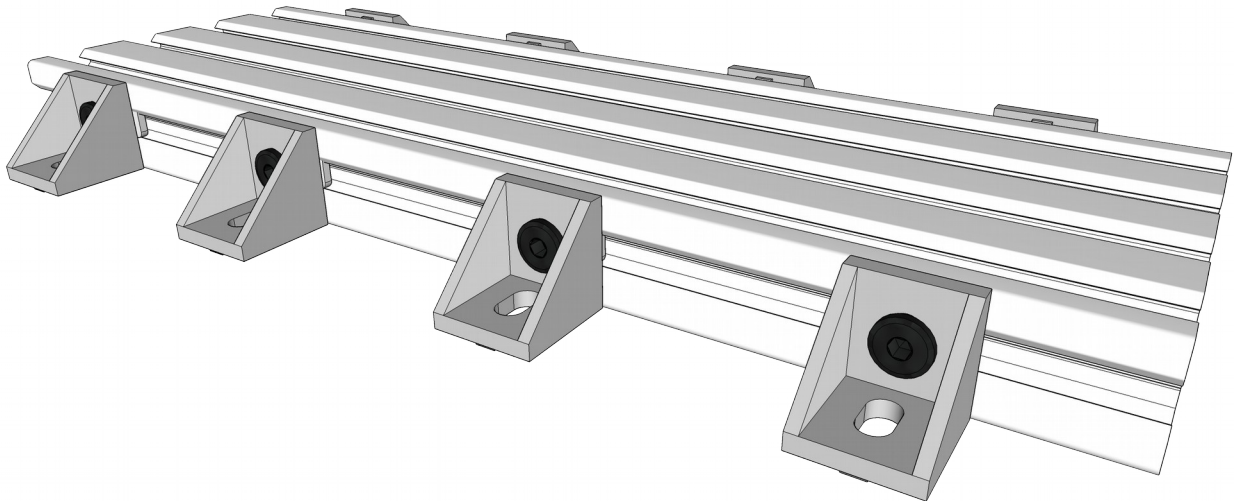
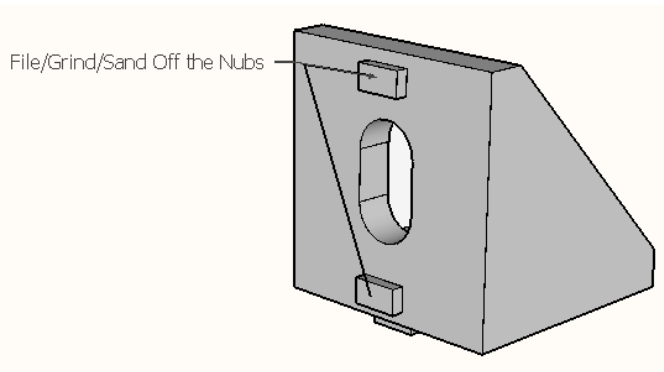

Figure 18: Backbone: Install the Cast Corners



You can improve the fit of the Cast Corners when used in orientations that do not allow the nubs to sit inside a V-Slot by removing the little nubs, as shown. Use a metal file, grinder, sander or some hand sanding to file the nubs down flat.

3.3.12 Assemble the Z Axis: Install Backbone

Using (8) M5 x 8mm Low Profile Screws, install the 20x80 V-Slot Linear Rail onto the back side of the X-Carriage assembly, as shown:

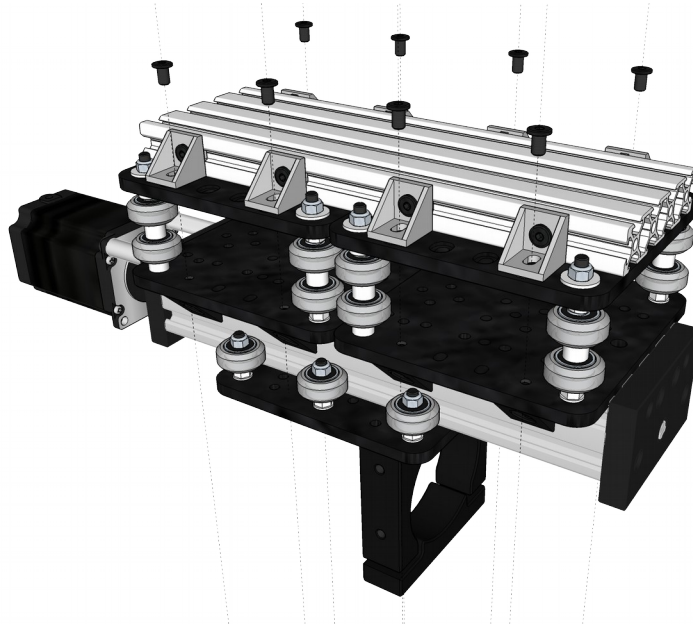

Figure 19: Assemble Z Axis: Install Backbone onto X Carriages

3.3.13 Actuator Assembly Complete

Repeat steps 3.3.1 – 3.3.13 to build the 2nd Actuator Assembly needed for the Triple-Z

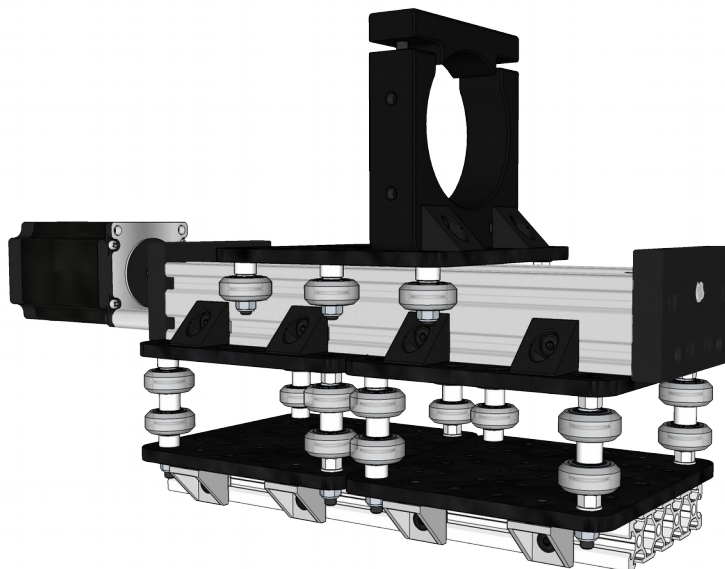
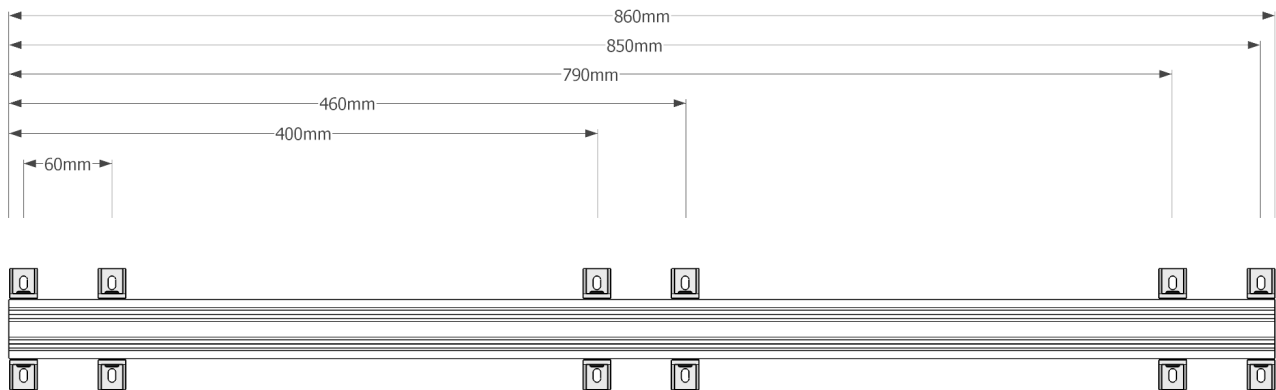

Figure 20: Completed Z-Axis Add On Assembly

3.4 Prepare Gantry Locking Beam - Triple-Z

3.4.1 Install the Corner Brackets

Using (12) M5 x 8mm Low Profile Screws and (12) M5 Tee Nuts, install (12) Cast Corners, as shown, onto the 860mm long 20x40 V-Slot Linear Rail. This will form the Gantry Locking Beam which transfers X-axis driving forces from the center carriage to the other two Z axis assemblies.



3.4.2 Install the Double End Caps

Install a Double End Cap onto each end of the Gantry Locking Beam using (2) M5 x 8mm Low Profile Screws, as shown.

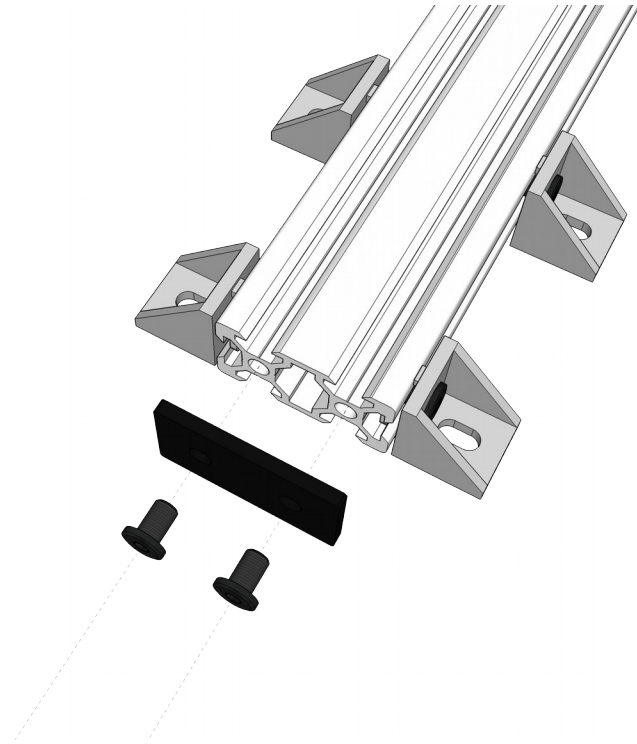

Figure 21: Install Gantry Locking Beam End Cap on the left

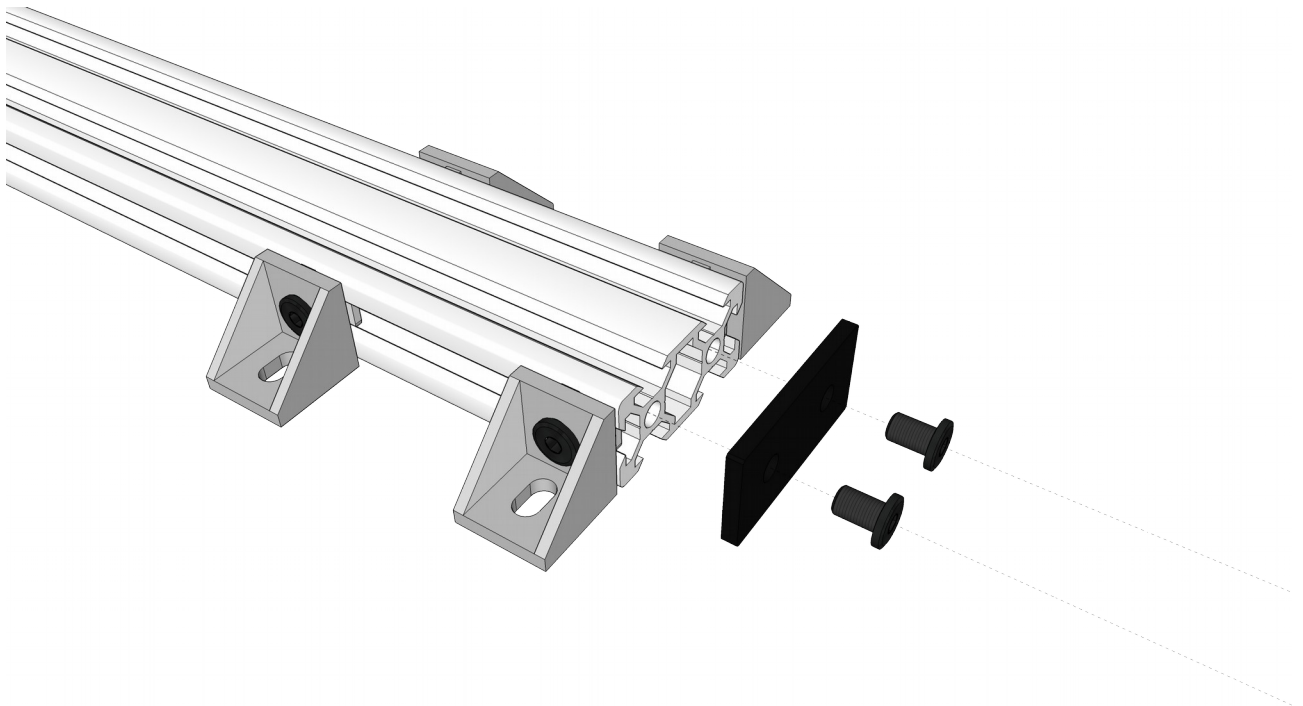

Figure 22: Install Gantry Locking Beam End Cap on the right

3.4.3 Install the Drop In Tee Nuts

Install (12) M5 Drop In Tee Nuts and (12) M5 x 8mm Low Profile Screws into the other face of the Cast Corner Brackets, as shown below

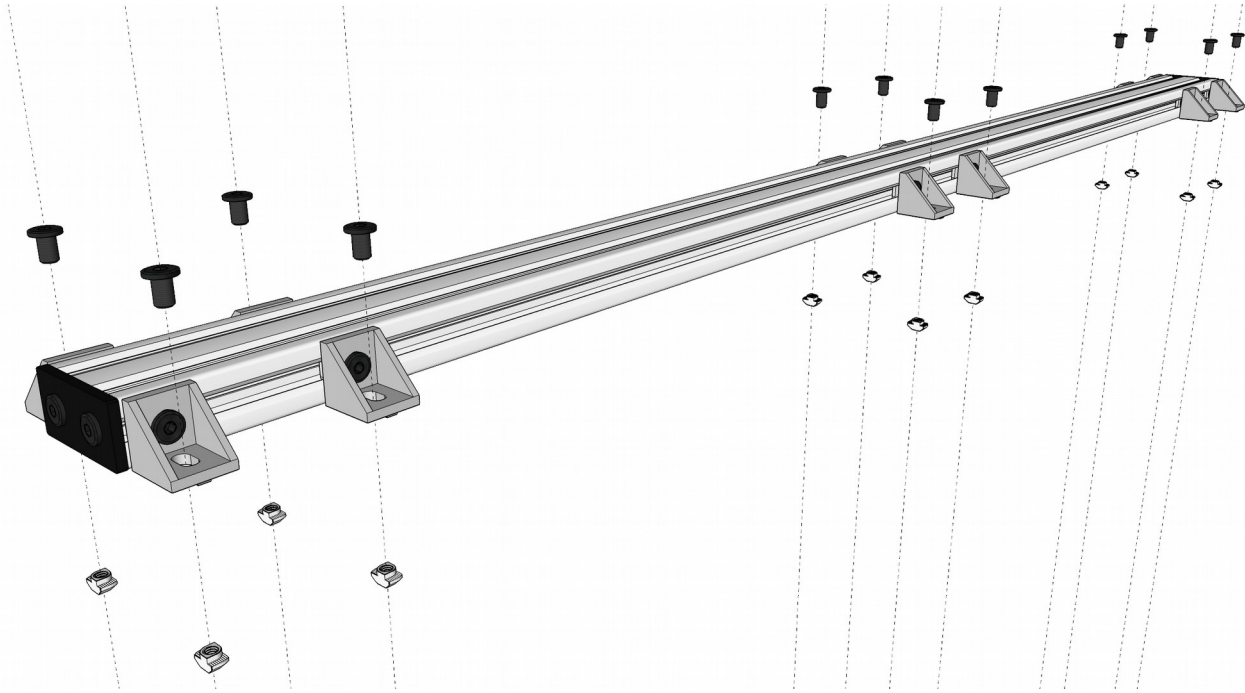

Figure 23: Install Drop In Tee Nuts

Make sure to leave the Drop In Tee Nuts loose as we will tighten them after inserting them into their respective slots later in the assembly.

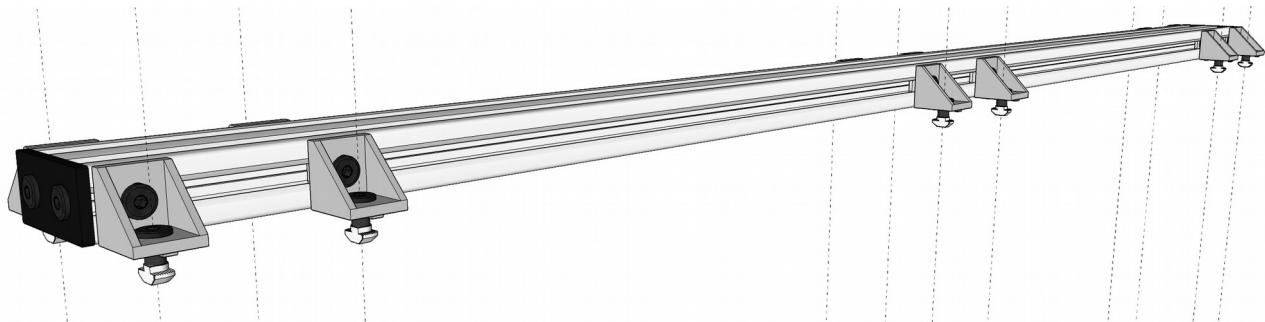

Figure 24: Drop In Tee Nuts Installed

4. Partially Disassemble your LEAD CNC Machine 1515

This guide assumes you have an already built LEAD CNC Machine 1515. If not, follow the Build Videos on <https://openbuilds.com/builds/openbuilds-lead-cnc-machine-1515-60-x-60.9552/> to perform the initial assembly and commissioning of your machine. Once it has been properly set up and working it is easier to install the Multi Z Add On onto the known working machine. The following section will guide you through taking some sections of your LEAD CNC Machine 1515 apart to install the Multi Z Add On components.

4.1 Remove X-Axis C-Beam end assemblies

You need unobstructed access to the X-Axis gantry to install the new Z Axis assemblies.

4.1.1 Left side (Triple-Z Only)

Remove the tensioning system from the left side of the lead screw as shown. Remove the End Mounts from the gantry beams on the left.

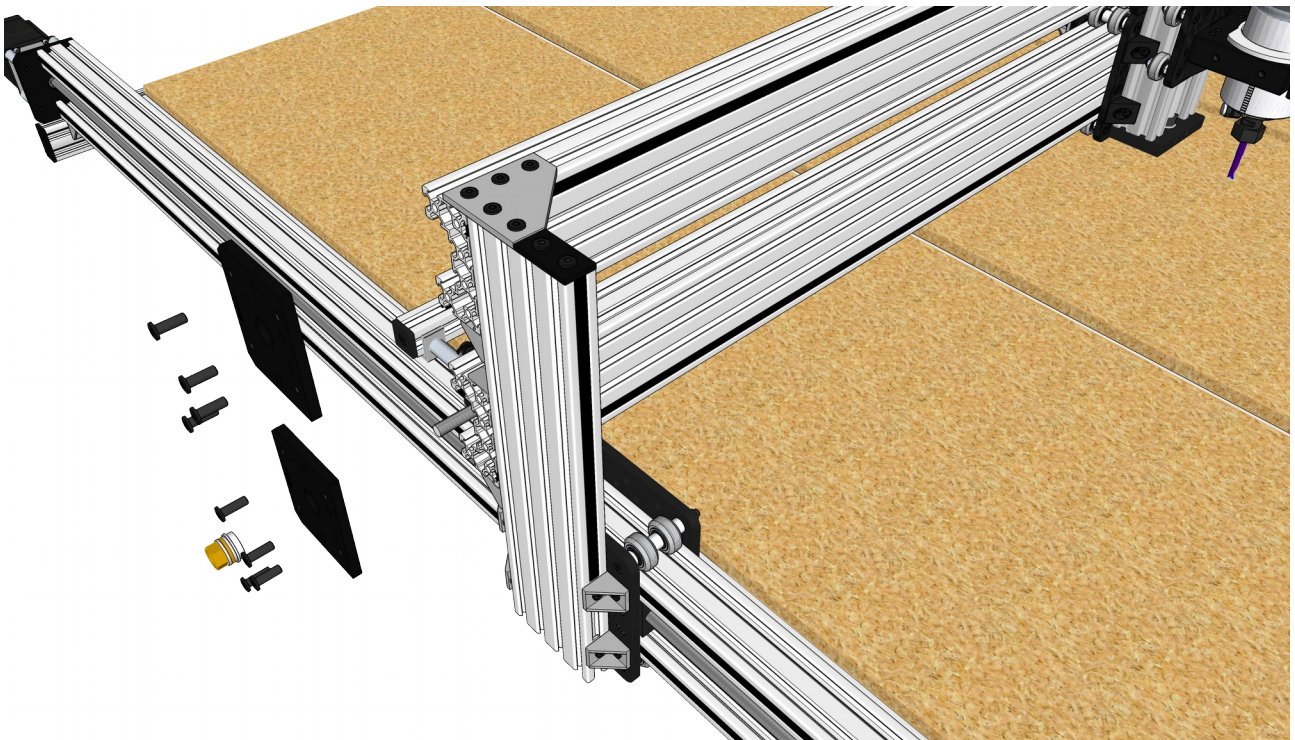

Figure 25: LEAD CNC Machine 1515 Disassembly: Disassemble Left Side

4.1.2 Right side

Remove the Stepper motor, bearings, and C-Beam End Mounts from the gantry beams on the right and set aside.

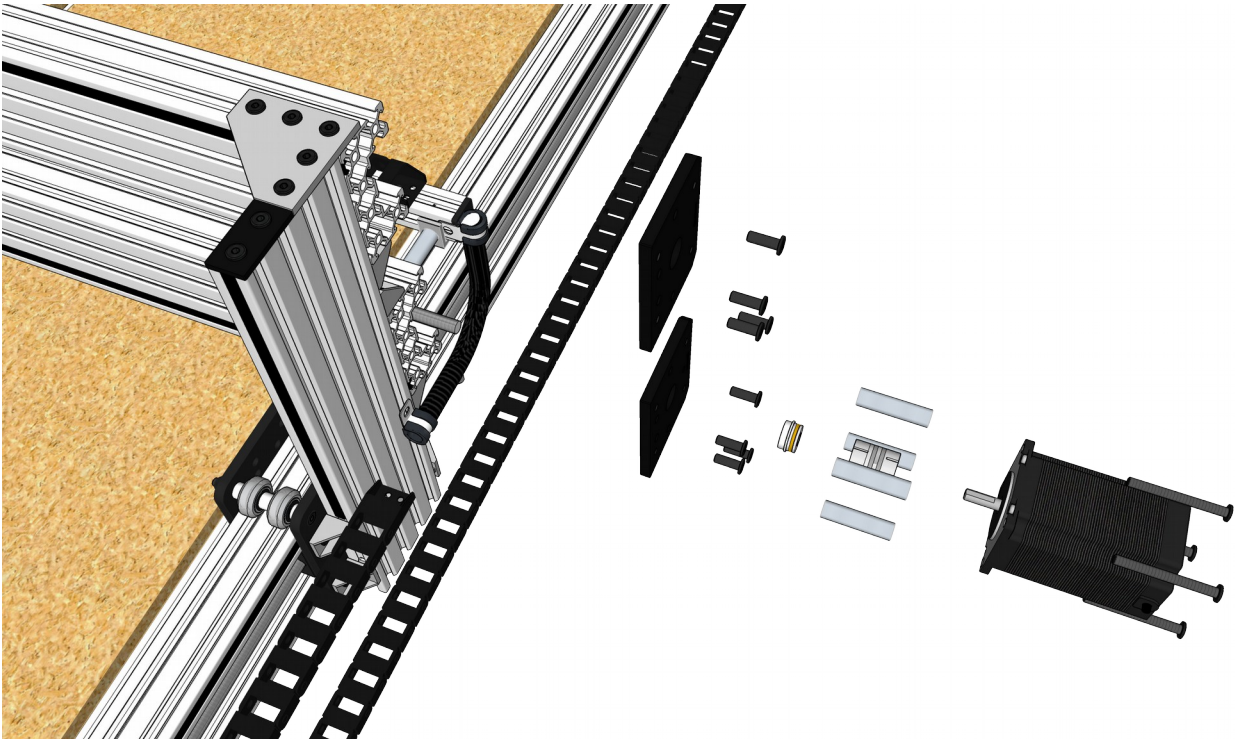

Figure 26: LEAD CNC Machine 1515 Disassembly: Disassemble Right Side

4.2 Remove the X Axis Drag Chain

4.2.1 Remove the Drag Chain carrier

Loosen the 20x20 V-Slot Linear Rail used as a cable chain carrier from the L-brackets.



Figure 27: LEAD CNC Machine 1515 Disassembly: Remove Cable Chain Carrier

Repeat for the other side:

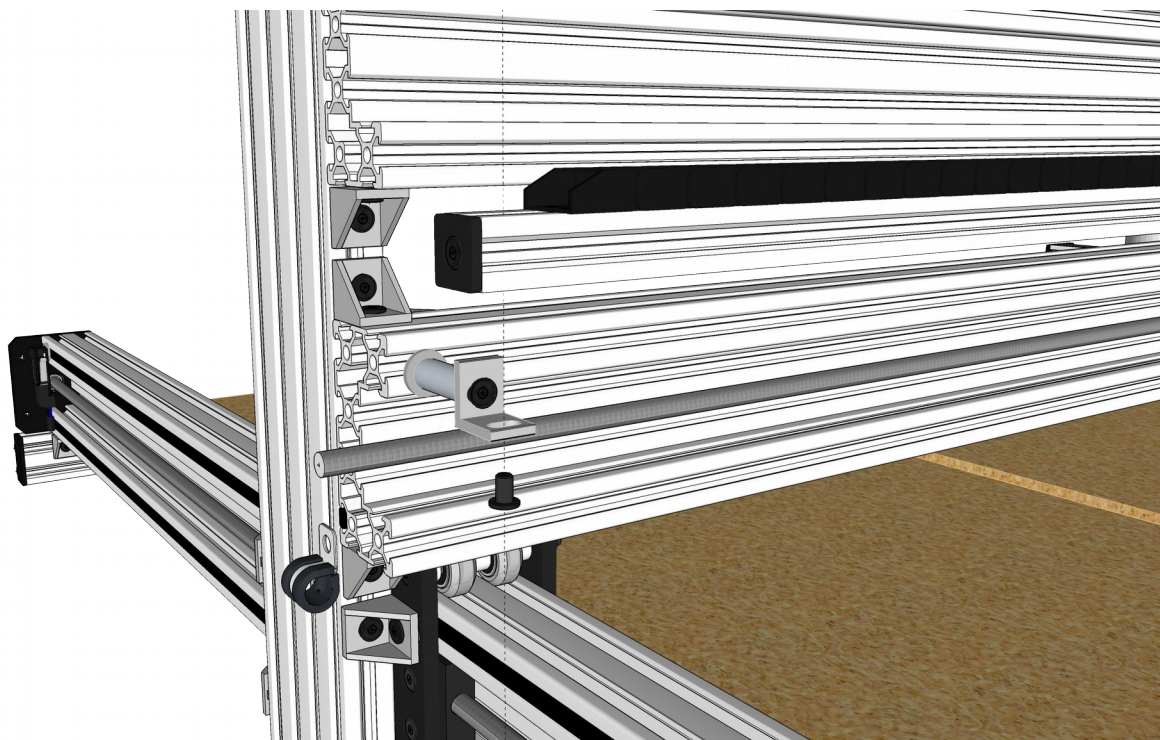

Figure 28: LEAD CNC Machine 1515 Disassembly: Remove Drag Chain Carrier

Lay it down behind the gantry. It needs to be far enough out of the way to slide on the new Z axis assemblies (See next section of the documentation)

Next, remove the Spacer assemblies as well:

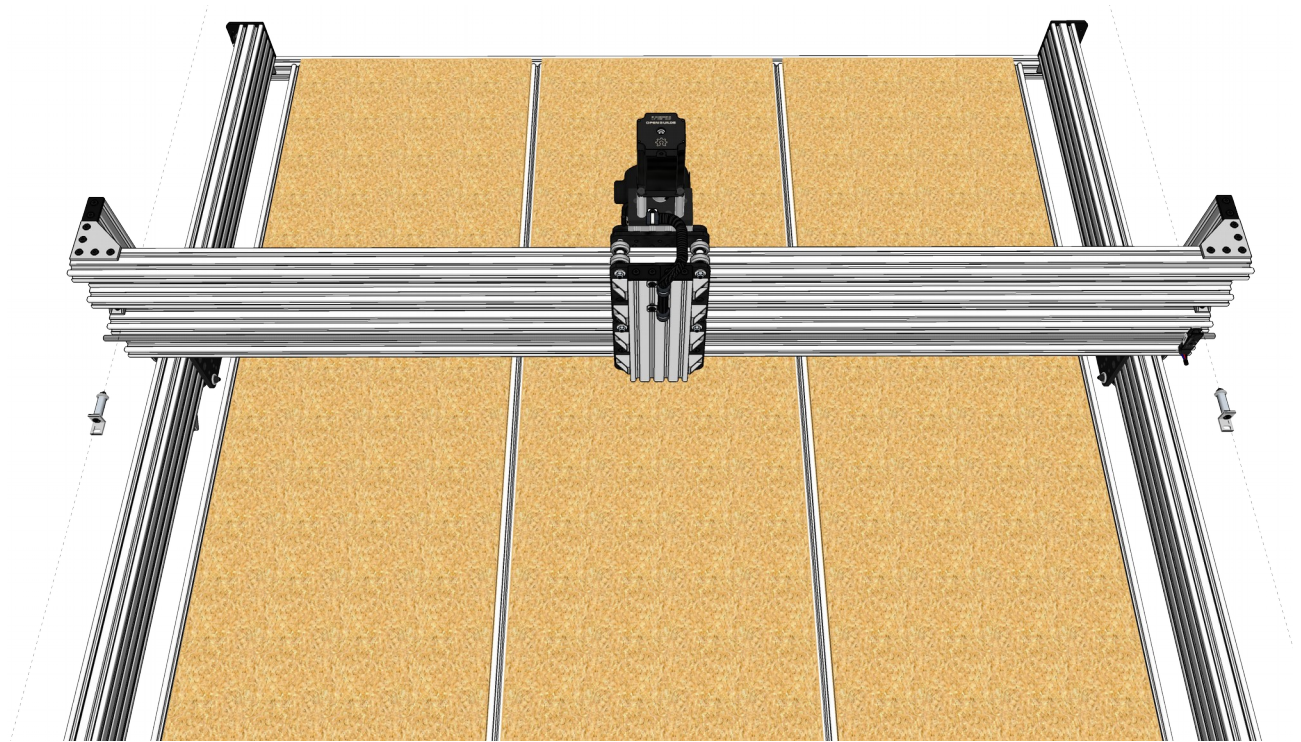

Figure 29: LEAD CNC Machine 1515 Disassembly: Remove Cable Chain Carrier

4.2.2 Remove the X-Axis Xtension Limit Switch (Triple-Z Only)

Take the X axis Xtension Limit Switch off and set it aside

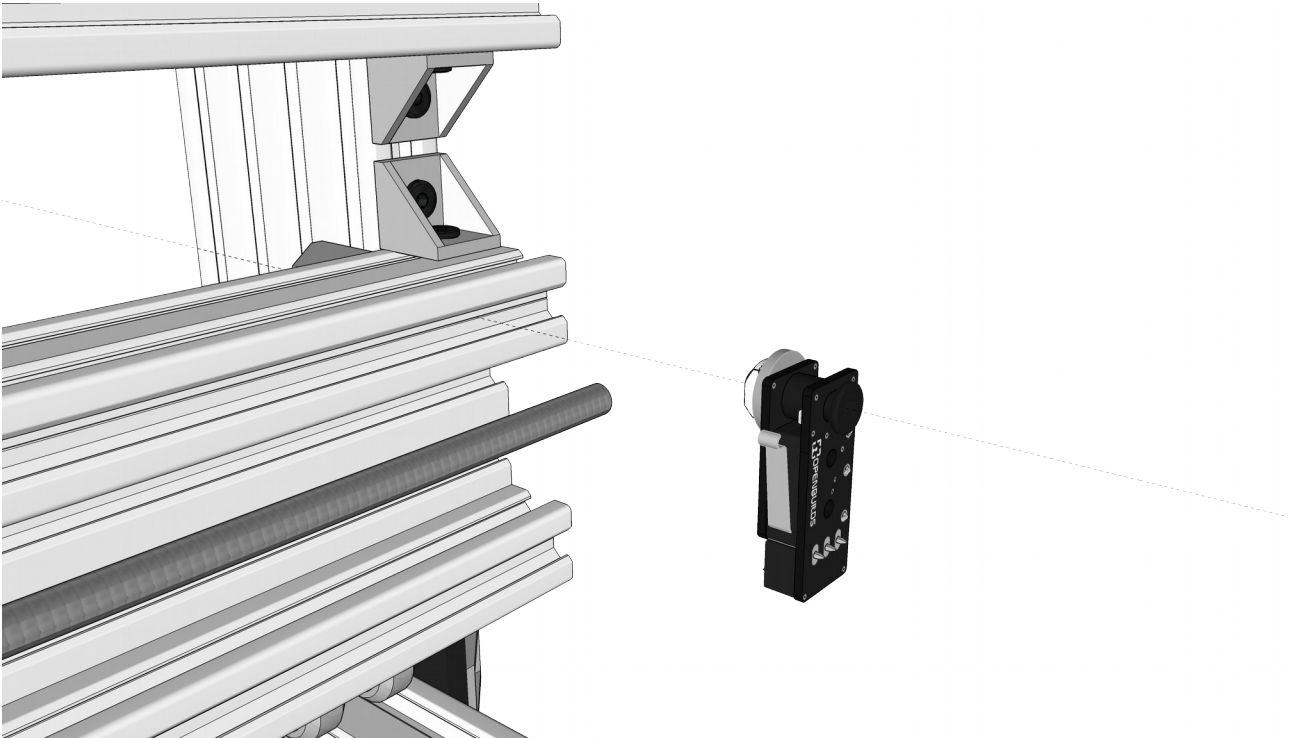

Figure 30: LEAD CNC Machine 1515 Disassembly: Remove X-Axis Xtension Limit Switch



Mark the position of the X-Axis Xtension Limit Switch prior to removal. This will allow you to reinstall it in the correct location with ease later on in the process.

5. Install the new Z Axis assemblies

5.1 Install the Left Side Z Axis (Triple-Z Only)

5.1.1 Disconnect the two gantry beams from the left side upright

Loosen the M5 Low Profile Screws, as shown, and set them aside.

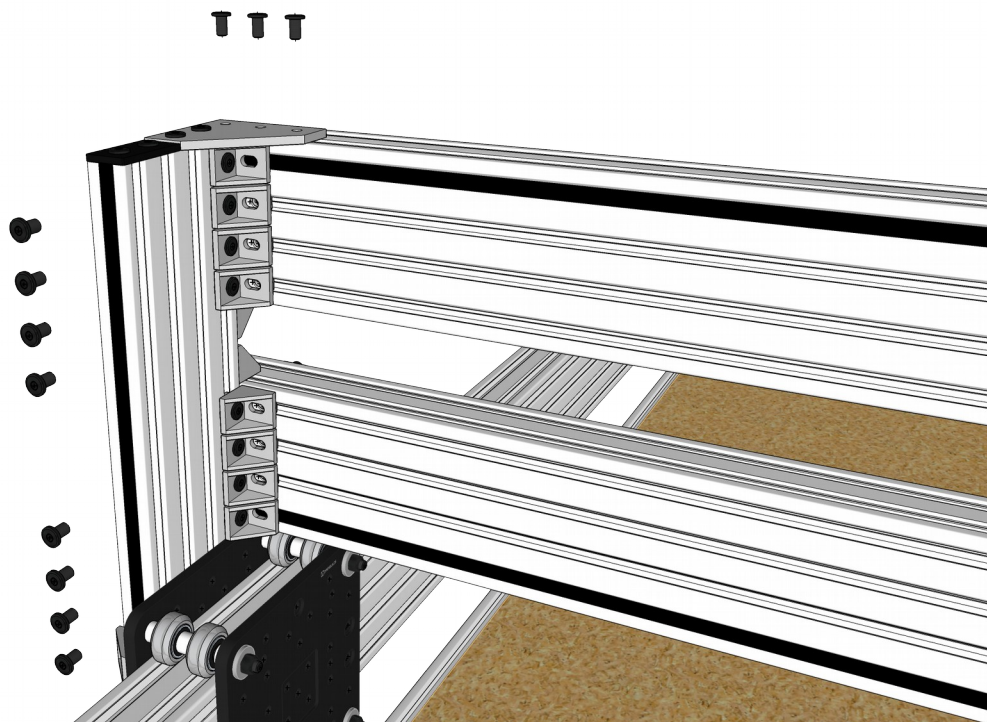

Figure 31: Loosen left side uprights from gantry

5.1.2 Loosen the C-Beam Linear Rail from the rear Cast Corners on the left

Also, loosen the screws holding the X axis C-Beam Linear Rails to the back side Cast Corners, as shown, to allow the C-Beam Linear Rails to separate completely from the uprights.

Leave the Cast Corners screwed to the uprights. They will help you reattach the C-Beam Linear Rails at the same height they were previously.

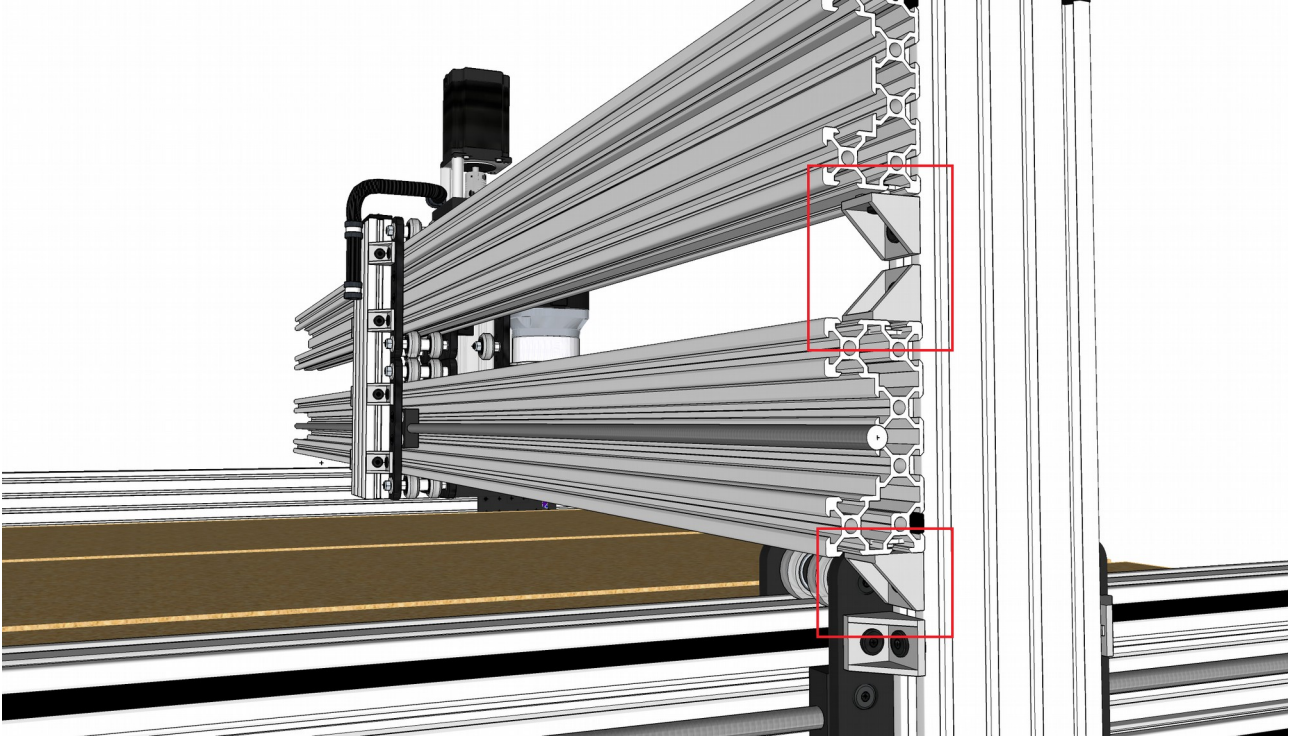

Figure 32: Loosen gantry beams from Cast Corners

5.1.3 Move the Left side Upright forward

IMPORTANT! Unplug the left Y axis motor. If you attempt to move it while plugged in it may damage your electronics. Proceed to turn only the left side Lead Screw/Flexible Coupling by hand moving the carriage forward at least 250mm. Call in a second pair of hands to help support the gantry or prop it up on supports.

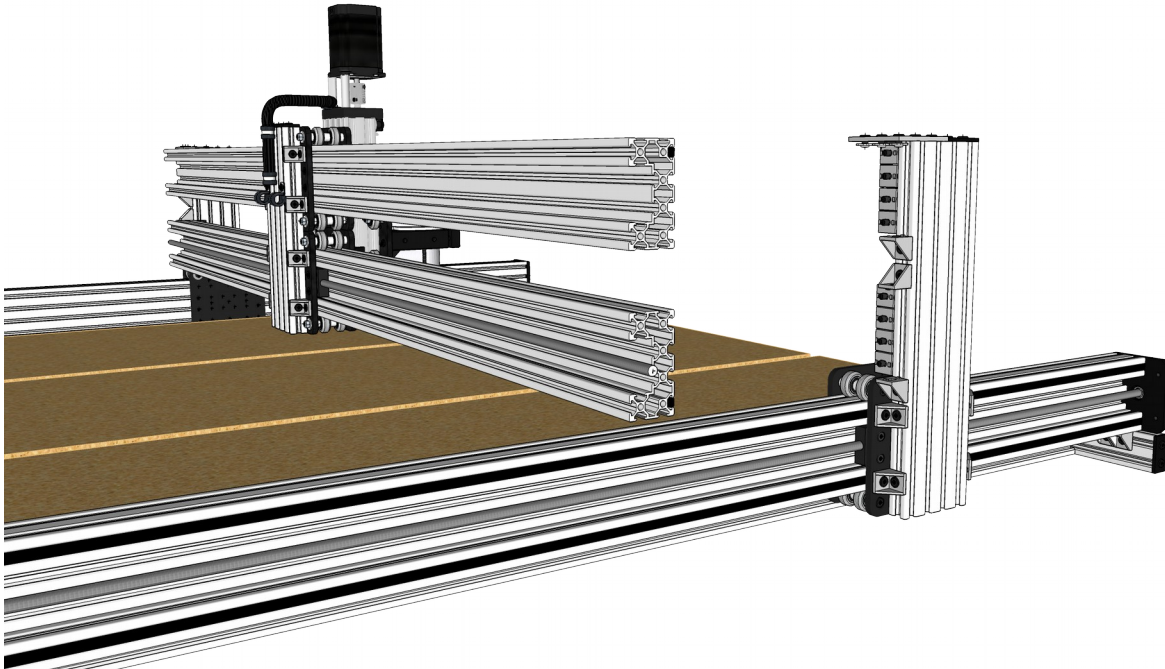

Figure 33: Move left side carriage forward

5.1.4 Remove the (3) Tee Nuts

Slide out the (3) Tee nuts left behind in the top front slot (used to attach the 90 degree joining plate) and set them aside.

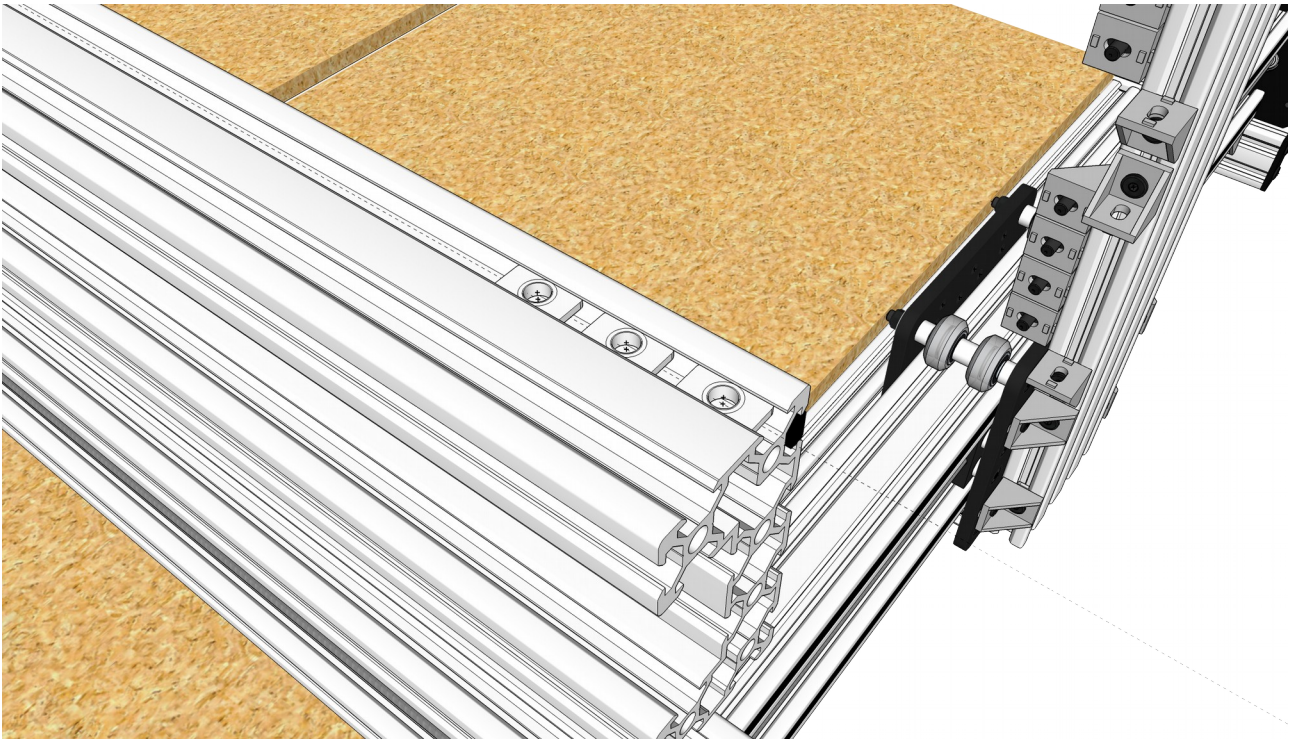

Figure 34: Remove the (3) Tee Nuts

5.1.5 Slide in the new left side Z axis Assembly

Slide in the Z axis assembly. Slide in the previously removed (3) Tee Nuts, as shown

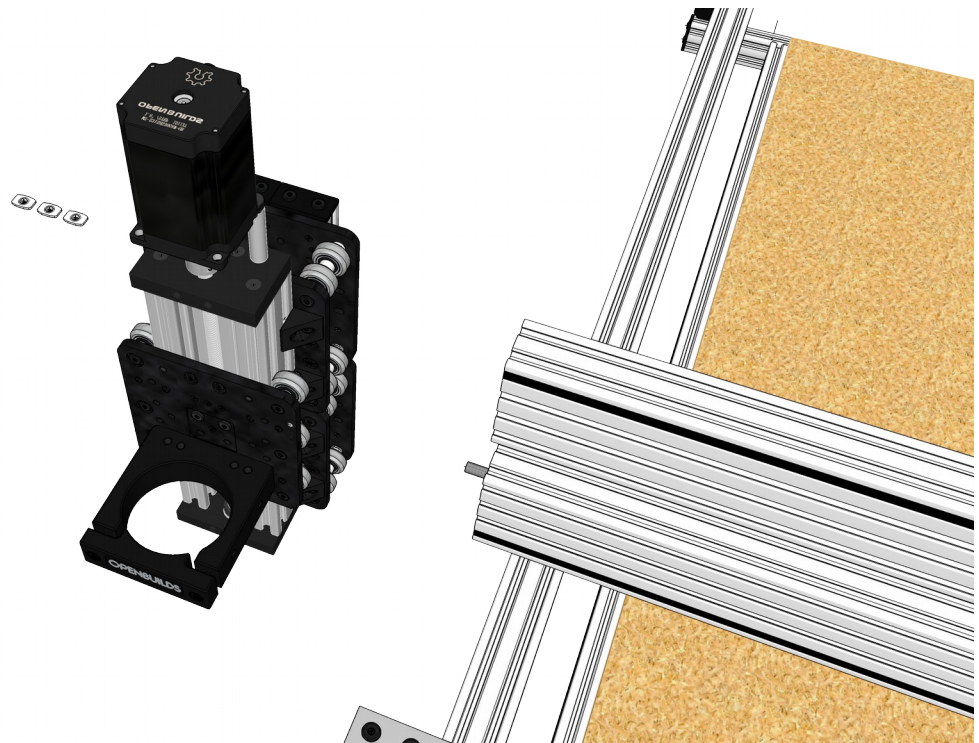

Figure 35: Slide on new Z assembly

5.1.6 Move the Left side Upright back and re-attach

With the new Z axis assembly slid onto the gantry, bring the Y axis carriage back by rotating the Lead Screw/Flexible Coupling, as before. Once its back in position, reinstall and tighten all fasteners to secure the gantry beams back to the uprights as it was before.

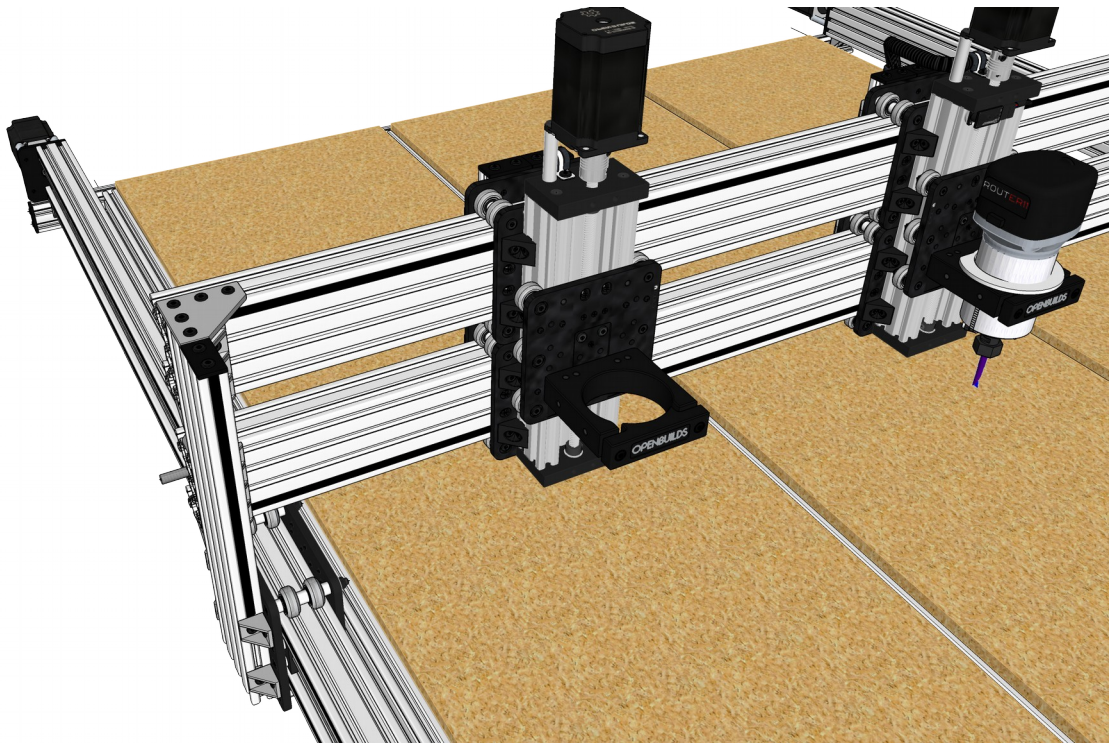

Figure 36: Reassemble gantry and upright

5.2 Install the Right Side Z Axis

5.2.1 Disconnect the two gantry beams from the right side upright

Loosen the M5 screws, as shown, and set them aside.

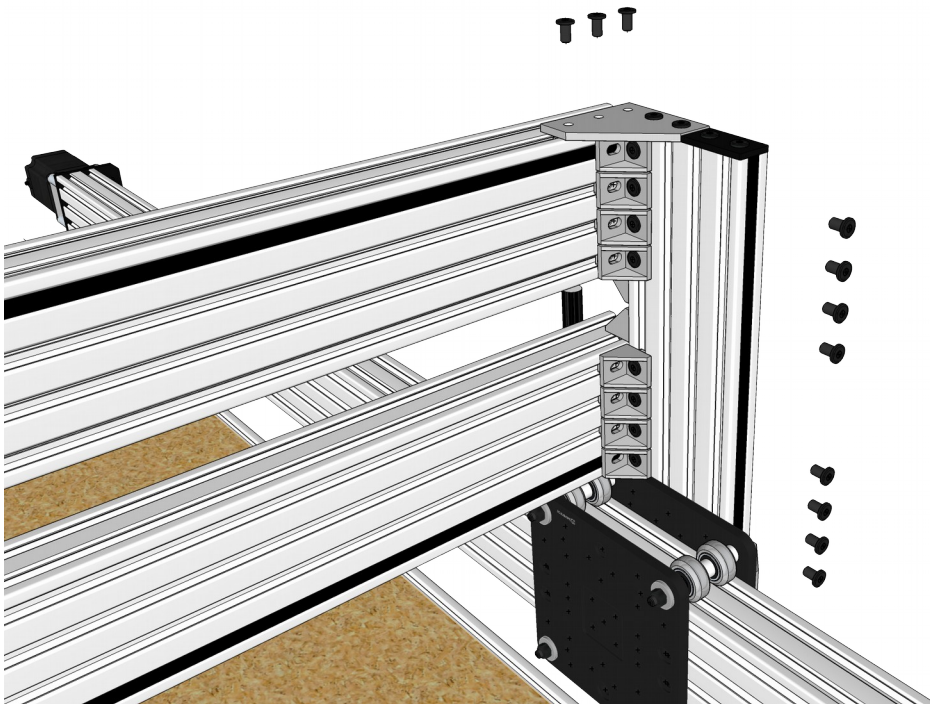

Figure 37: Loosen right side uprights from gantry

5.2.2 Loosen the C-Beam Linear Rail from the rear Cast Corners on the left

Also loosen the screws holding the X axis C-Beam Linear Rails to the back side Cast Corners, as shown, to allow the C-Beam Linear Rails to separate completely from the uprights.

Leave the Cast Corners screwed to the uprights. They will help you reattach the C-Beam Linear Rails at the same height they were before.

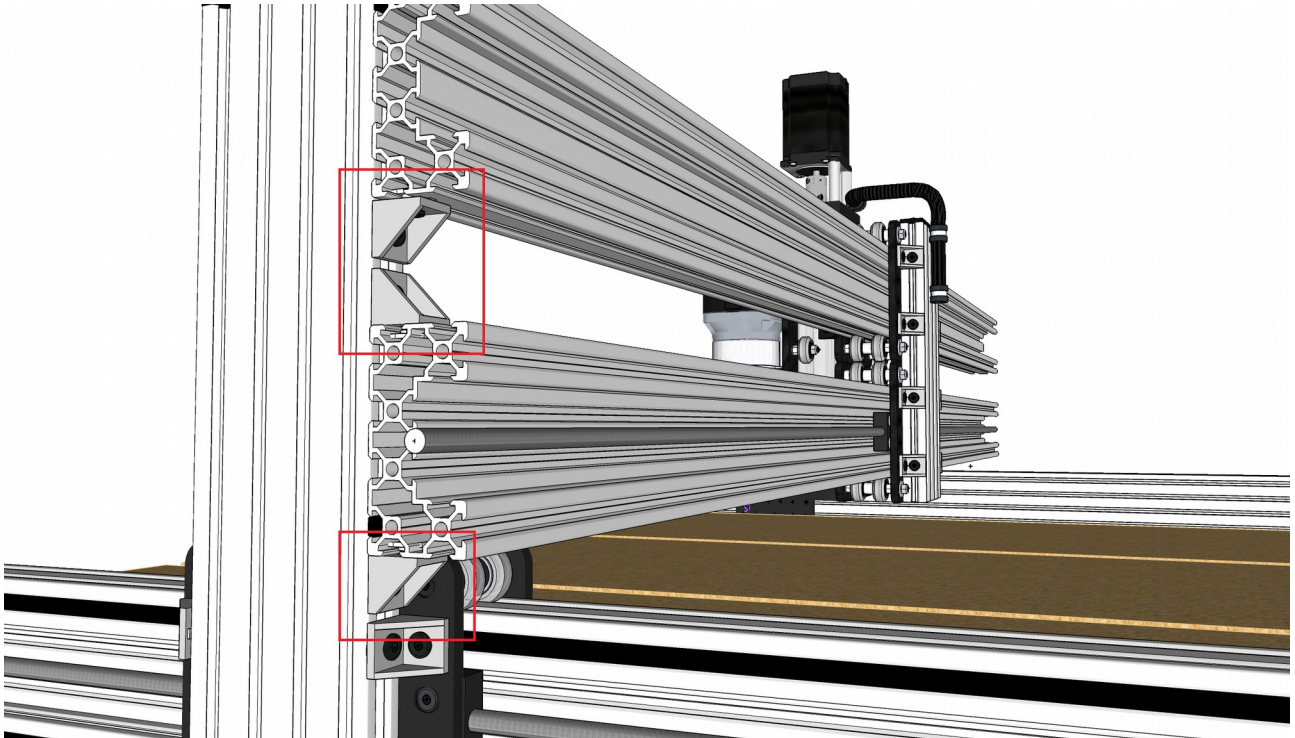

Figure 38: Loosen gantry beams from cast corner brackets

5.2.3 Move the Right side Upright forward

IMPORTANT! Unplug the right Y axis motor. If you attempt to move it while plugged in, it may damage your electronics. Proceed to turn only the right side Lead Screw/Flexible Coupling by hand moving the carriage forward at least 250mm. Call in a second pair of hands to help support the gantry or prop it up on supports.

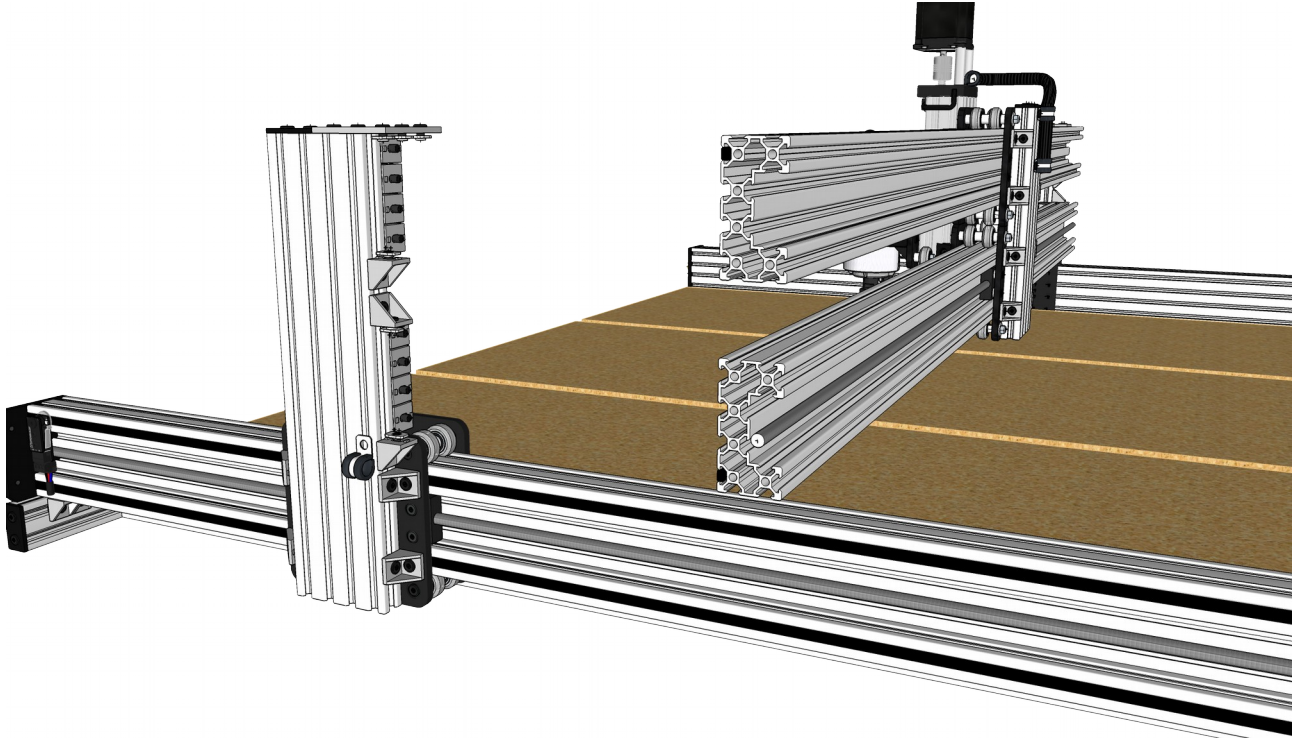

Figure 39: Move right side carriage forward

5.2.4 Remove the (3 Tee Nuts)

Slide out the (3) Tee Nuts left behind in the top front slot (used to attach the 90 degree joining plate) and set them aside.

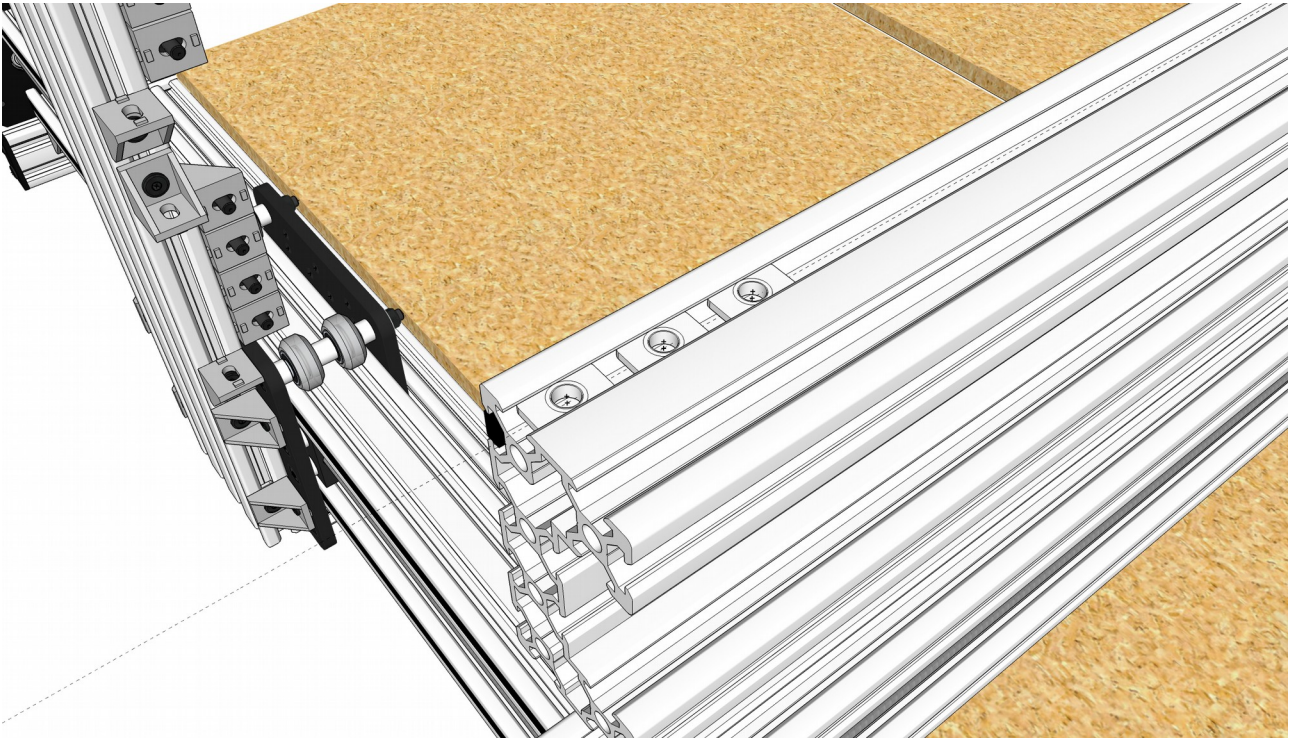
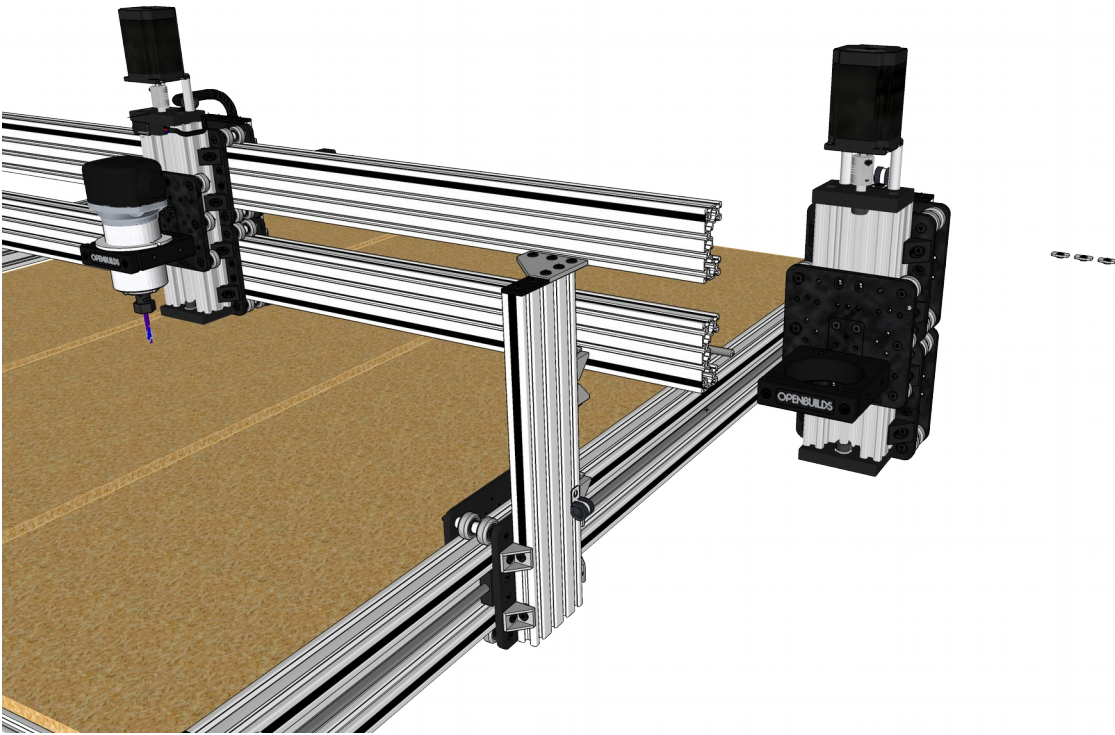

Figure 40: Remove the 3x Tee Nuts

5.2.5 Slide in the new right side Z axis Assembly

Slide in the Z axis assembly. Slide in the previously removed (3) Tee Nuts, as shown



5.2.6 Move the Left side Upright back, and re-attach

With the new Z axis assembly slid onto the gantry, bring the Y axis carriage back by rotating the Lead Screw/Flexible Coupling, as before. Once its back in position, reinstall and tighten all fasteners to secure the gantry beams back to the uprights as it was before.

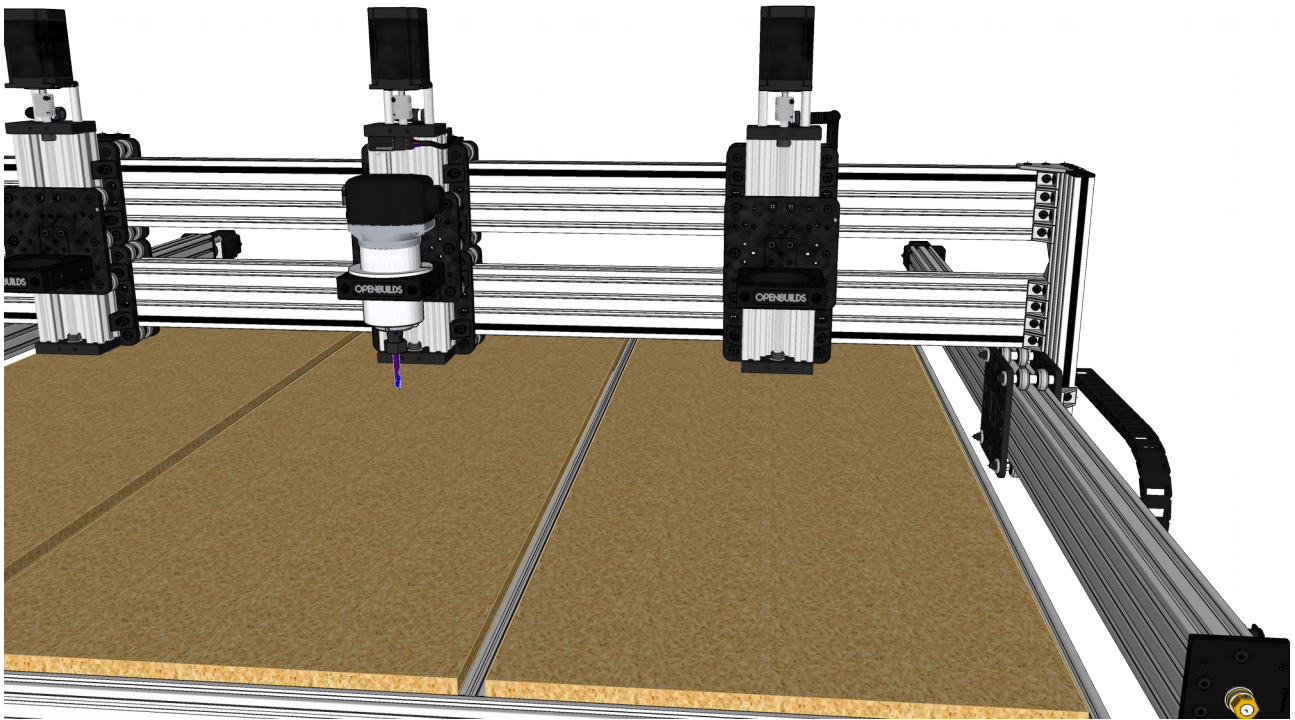

Figure 41: Reassemble gantry and upright

5.3 Install Gantry Locking Beam

5.3.1 Install the Gantry Locking Beam onto the Z-Axis assemblies

Position the Z axis assemblies with 390mm center-to-center spacing, and proceed to install the Gantry Locking Beam onto the 20x80 V-Slot Linear Rail, as shown.

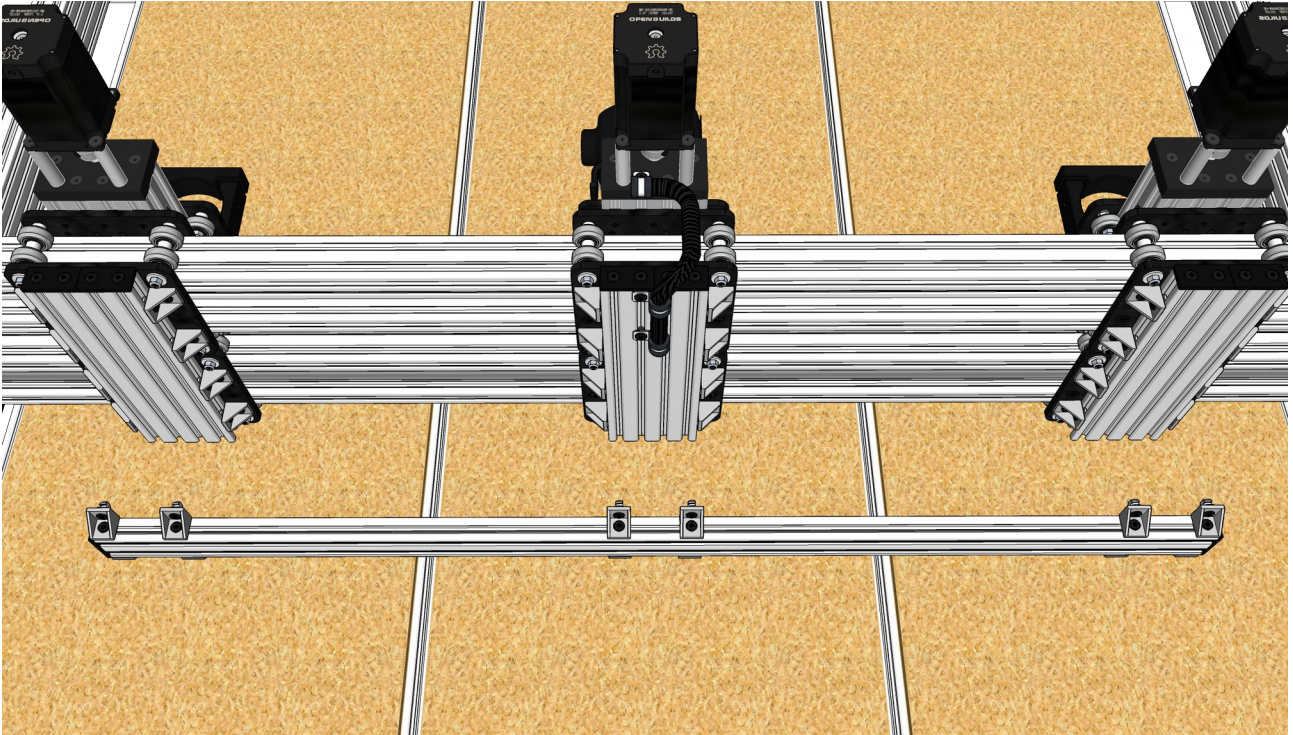

Figure 42: Install the Gantry Locking Beam

Position it in line with the bottom edge of the 20x80 V-Slot Linear Rail and proceed to make sure all the screws are tightened correctly ensuring the Tee Nut rotates into position correctly as well.

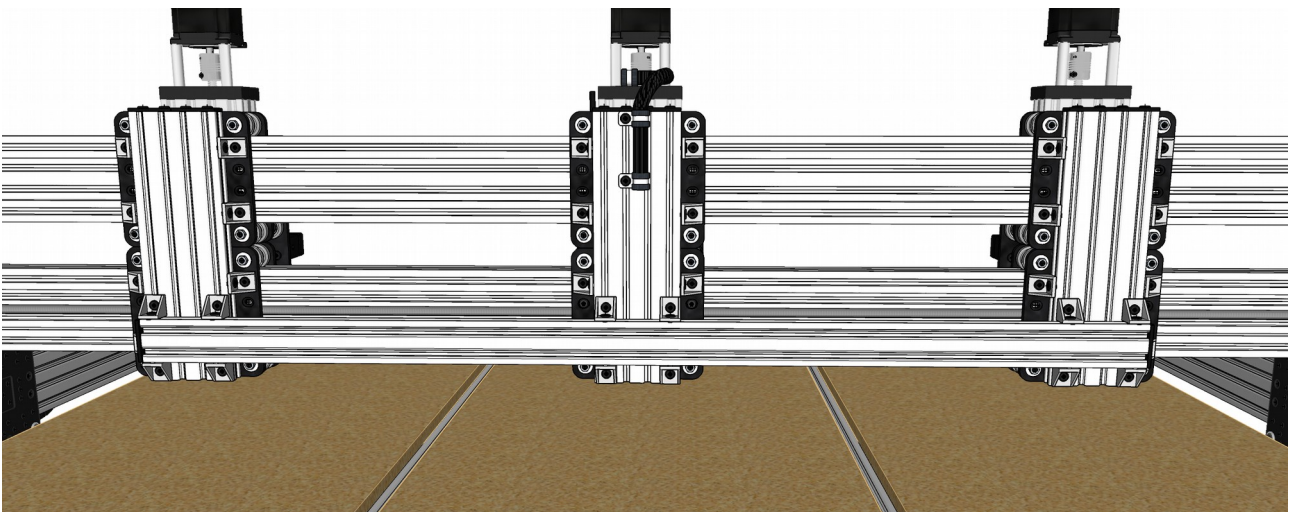
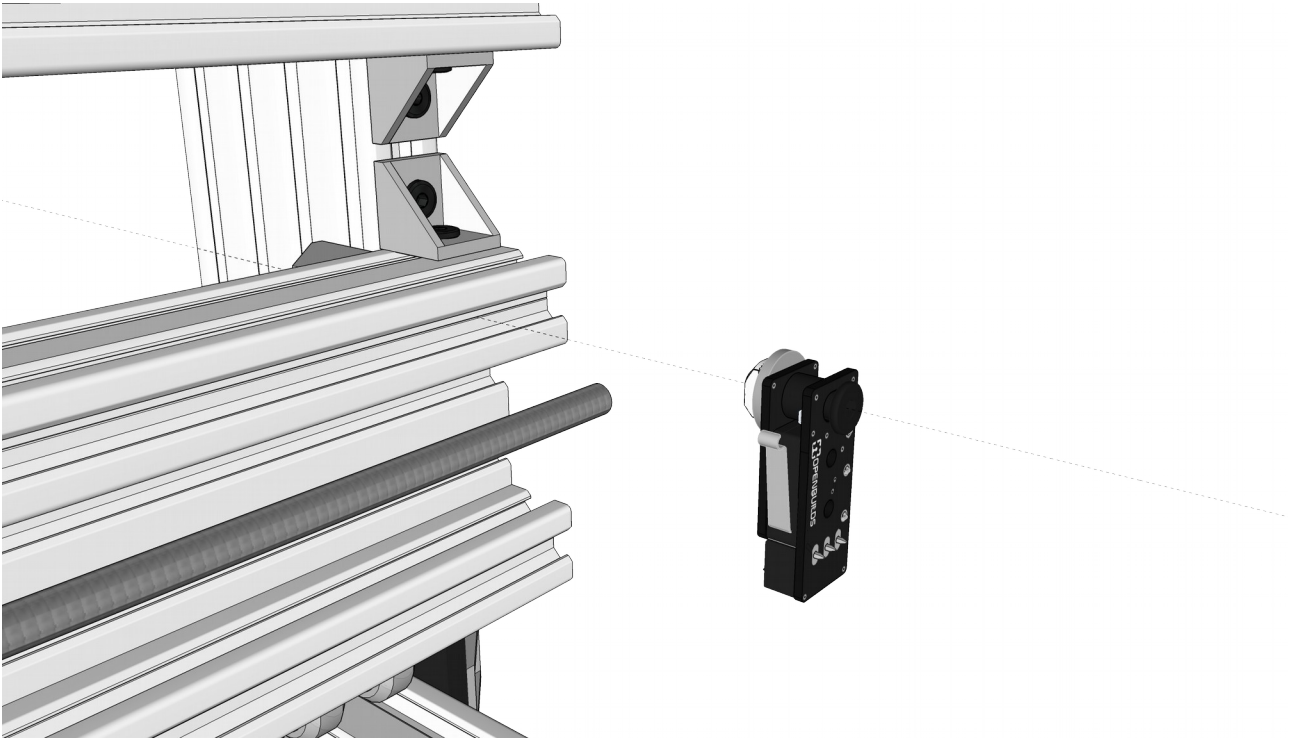

Figure 43: Gantry Locking Beam Installed

5.4 Reassemble Xtension Limit Swtiches and Drag Chain

5.4.1 Reinstall the X axis Xtension Limit Switch

Use the position you marked earlier to ensure its installed in the correct location.



5.4.2 Reinstall the Drag Chain spacers

Reinstall the Drag Chain spacers, as shown:

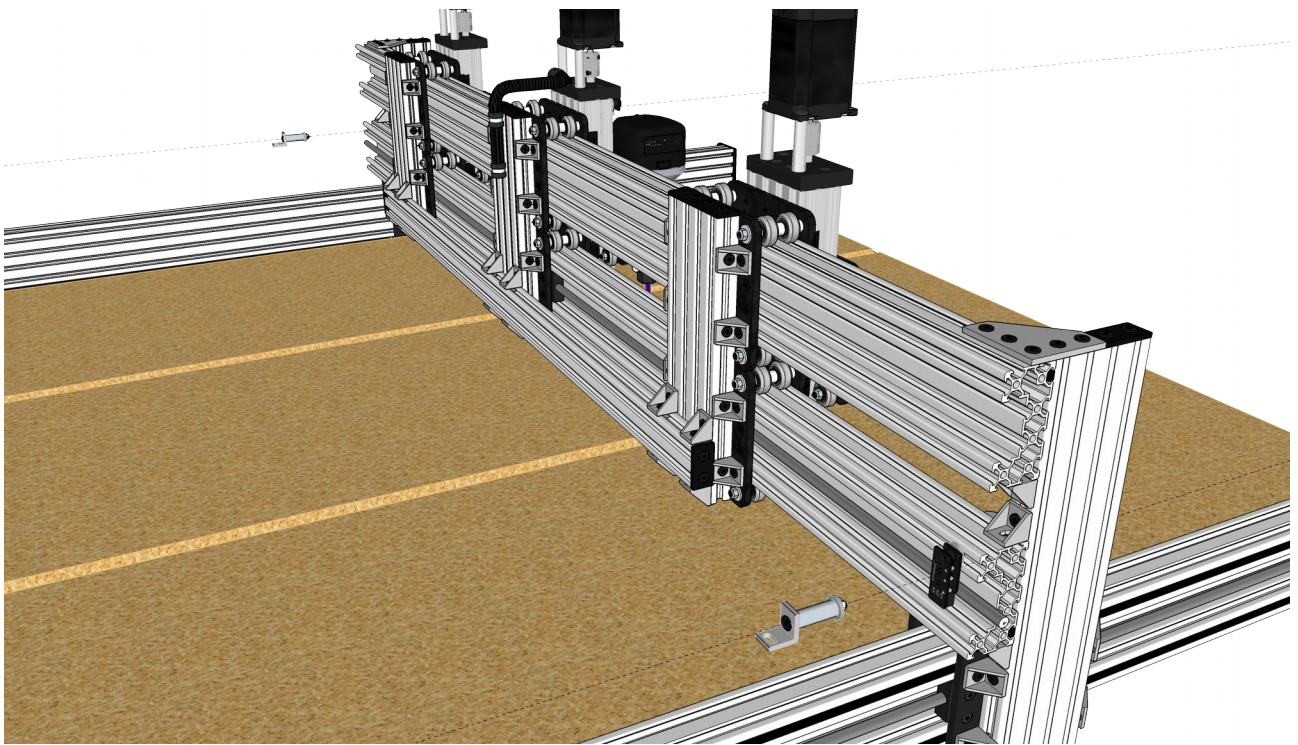

Figure 44: Reinstall Drag Chain spacers

5.4.3 Reinstall the Drag Chain carrier and Drag Chain

Install the 20x20 V-Slot Linear Rail used as a Drag Chain Carrier back onto the L-Brackets as it was before using the (2) M5 x 8mm Low Profile Screws and (2) M5 Tee Nuts.

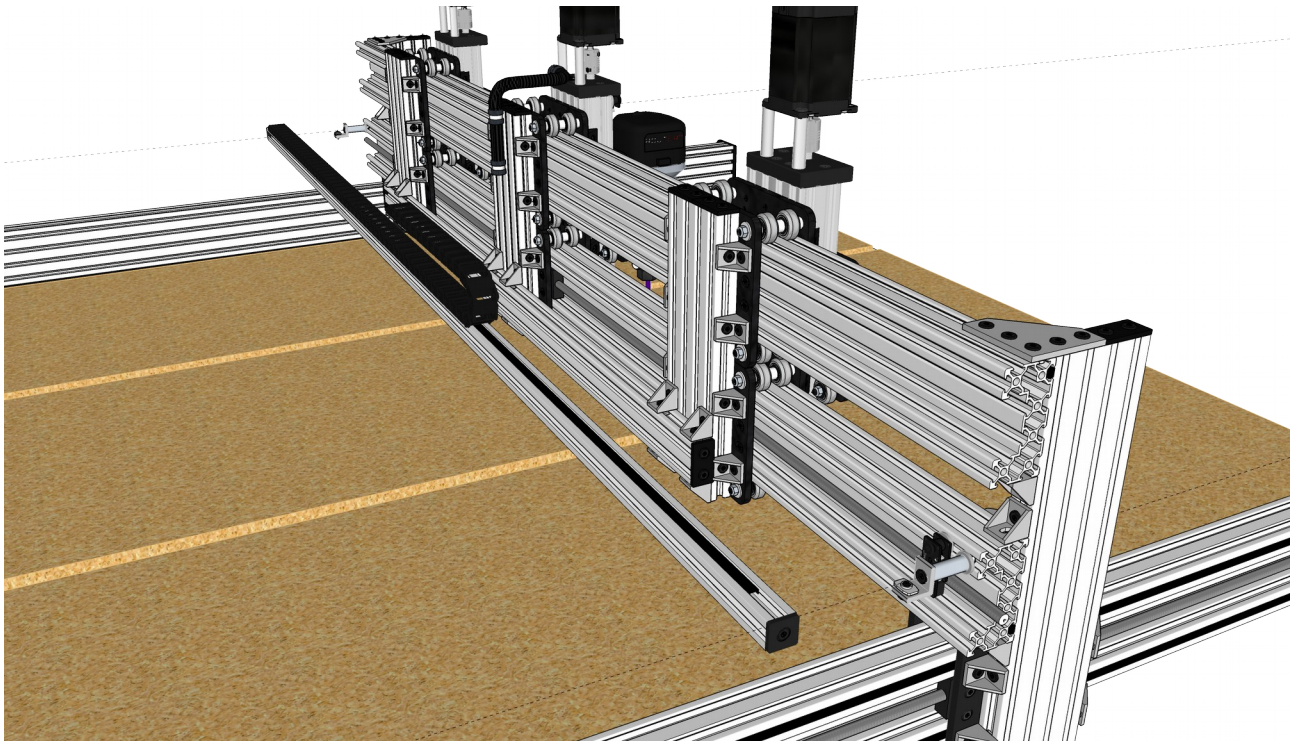
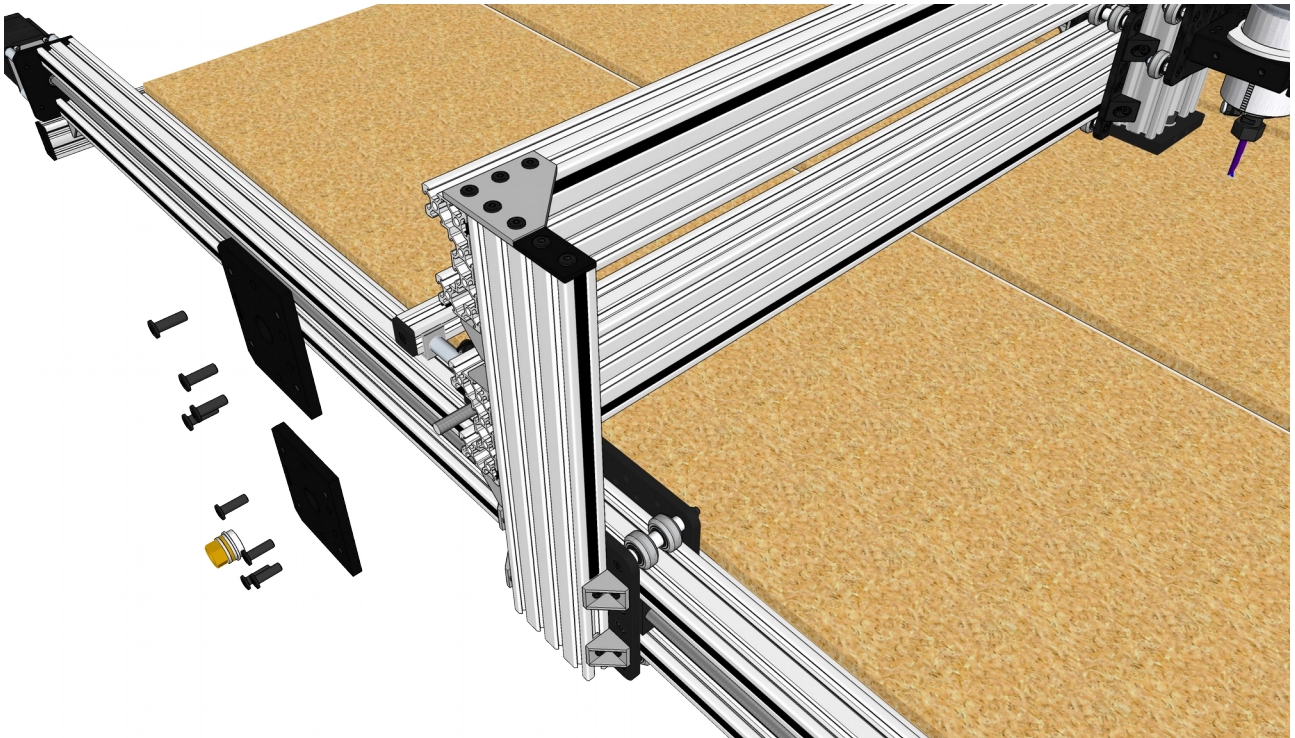

Figure 45: Reinstall Drag Chain Carrier and Drag chain

5.4.4 Reinstall the left side C-Beam End Mounts

Put the left side back together, as shown



5.4.5 Reinstall the right side C-Beam End Mounts and motor

Put the right side back together as shown

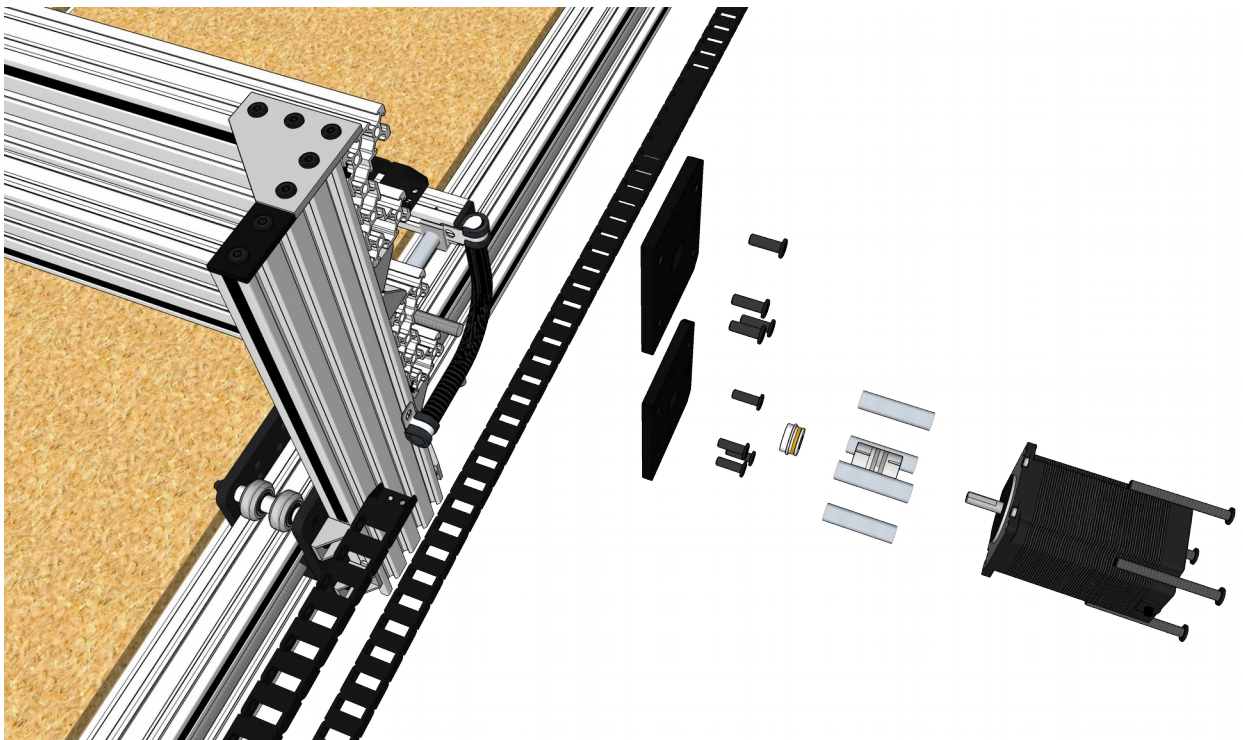

5.4.6 Re-tension the Lead Screw

Re-tension the X-Axis Lead Screw as you did during initial assembly (also shown in https://www.youtube.com/watch?v=gWsdWk9W_zQ)

6. Wiring

6.1 Wire additional Z-axis motors

The two additional Z-axis motors are wired in parallel to the existing Z-axis motor using a 4-way Screw Terminal Block:

6.1.1 Disassemble Z axis Backbone End caps

Unscrew the self tapping screws that hold the Double End Caps onto the 20x80mm V-Slot that forms the backbone of the existing Z axis assembly.

Remove the Screws and Double End Caps and set aside for now.

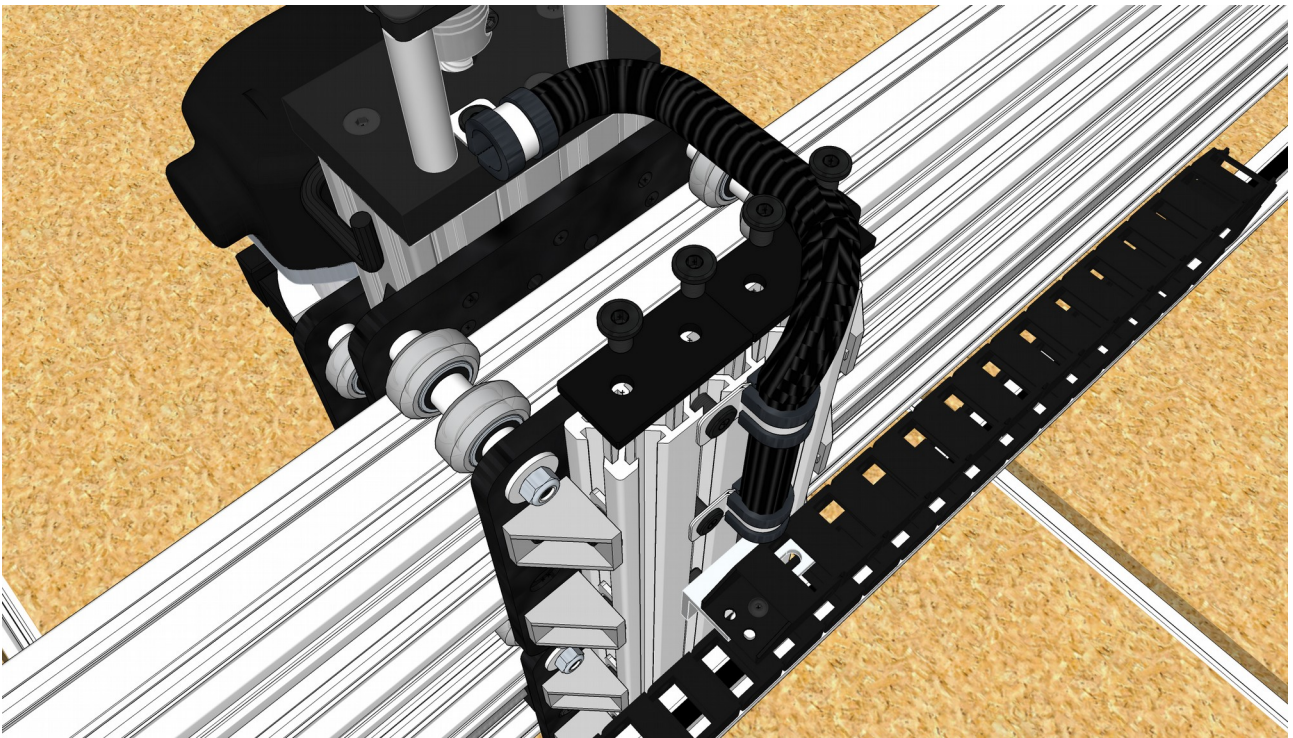

Figure 46: Remove the Double End Caps from the center Z axis backbone

6.1.2 Install Flex Tubing Clamps on center Z-axis Backbone

Shorten the existing Z-axis motors tube as shown, and remove one of the Flexible Tubing Clamps

Install (2) Flexible Tubing Clamps as shown using (2) M5x8mm Low Profile Screws and (2) M5 Tee Nuts

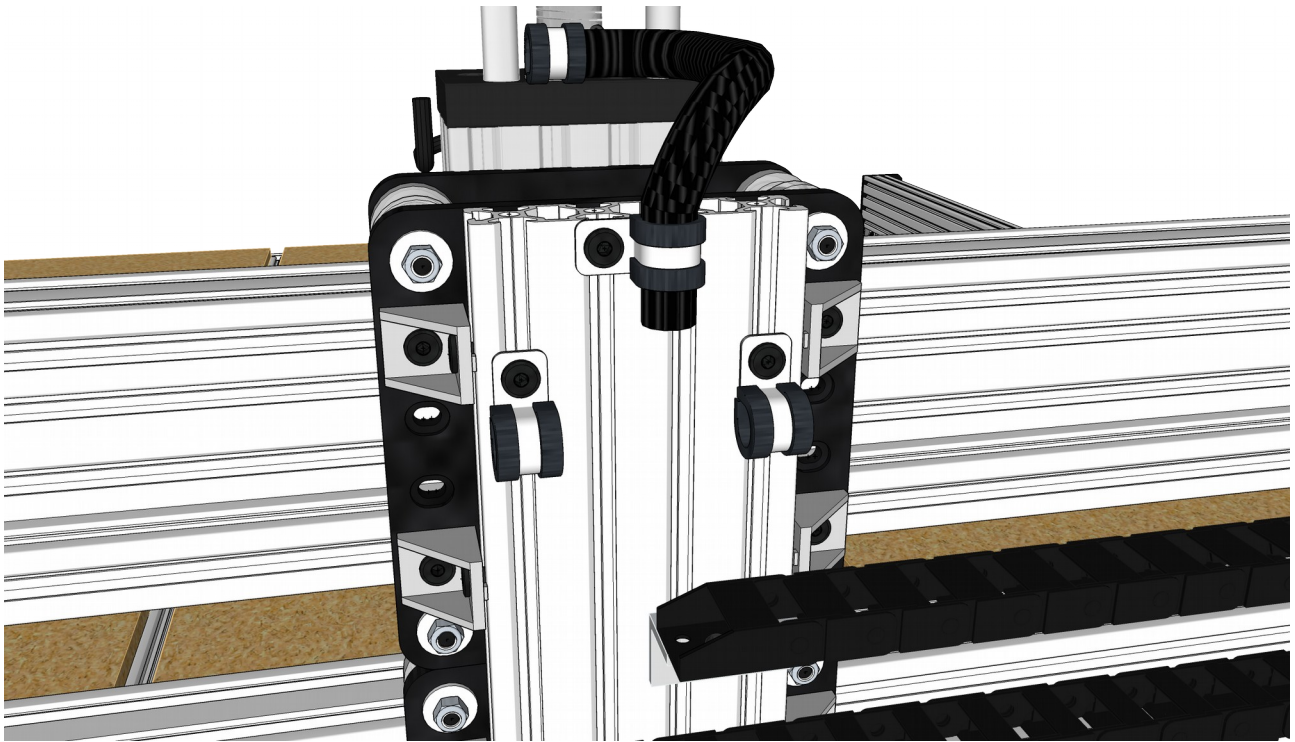

Figure 47: Install Flex Tubing Clamps on the center Z-axis Backbone

6.1.3 Install Flex Tubing Clamps on Additional Z-axis Backbones

Install (2) Flexible Tubing Clamps, as shown, using (2) M5x8mm Low Profile Screws and (2) M5 Tee Nuts onto each of the two new Z axis assemblies.

Install (1) Flexible Tubing Clamp under one of the existing M5x20mm Low Profile Screws used for the C-Beam End Mount

Repeat for the other new Z axis assembly.

This will allow you to install Flexible Tubing between the new Z axis assemblies and the original Z-axis in the center.

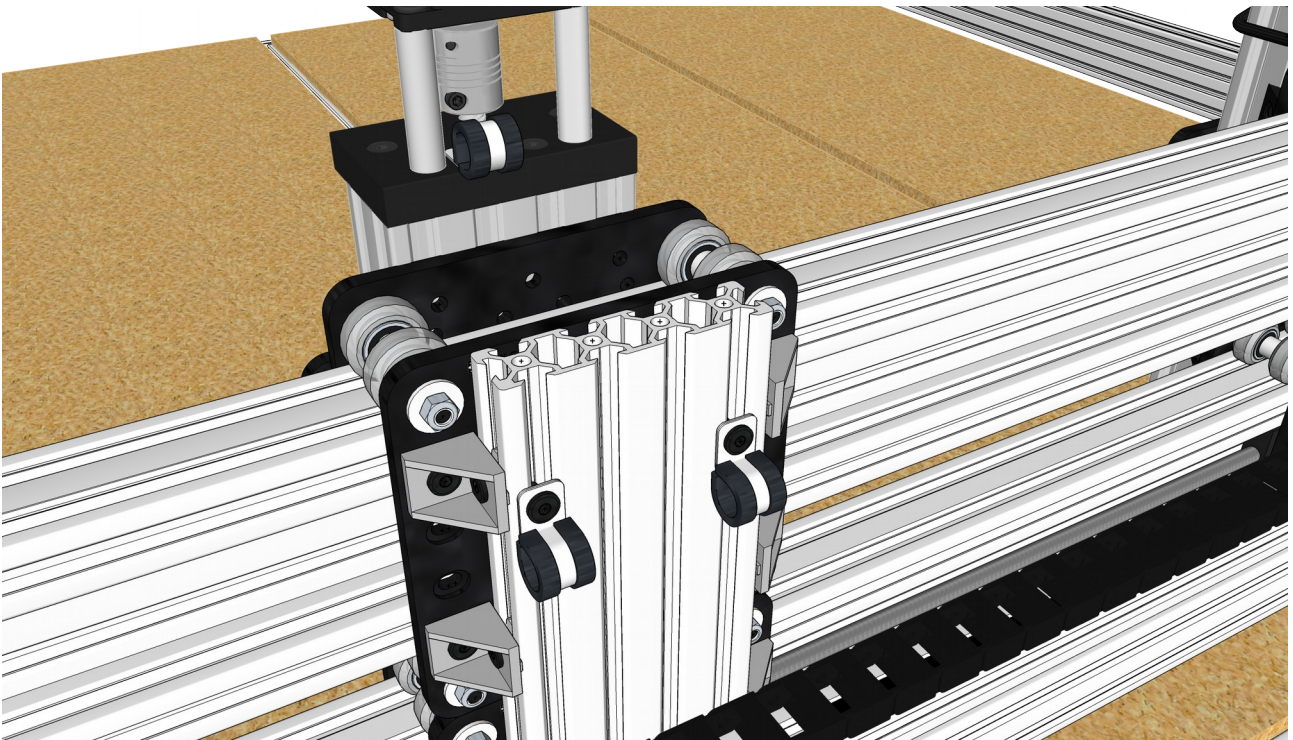

Figure 48: Install Flexible Tubing Clamps on the additional Z-axis backbones

6.1.4 Install flex tubing

From the provided (2) pieces of 3ft Flex Tubing, install Flex Tubing between the original Z axis and each of the new Z-axis assemblies as shown, cutting to length as needed

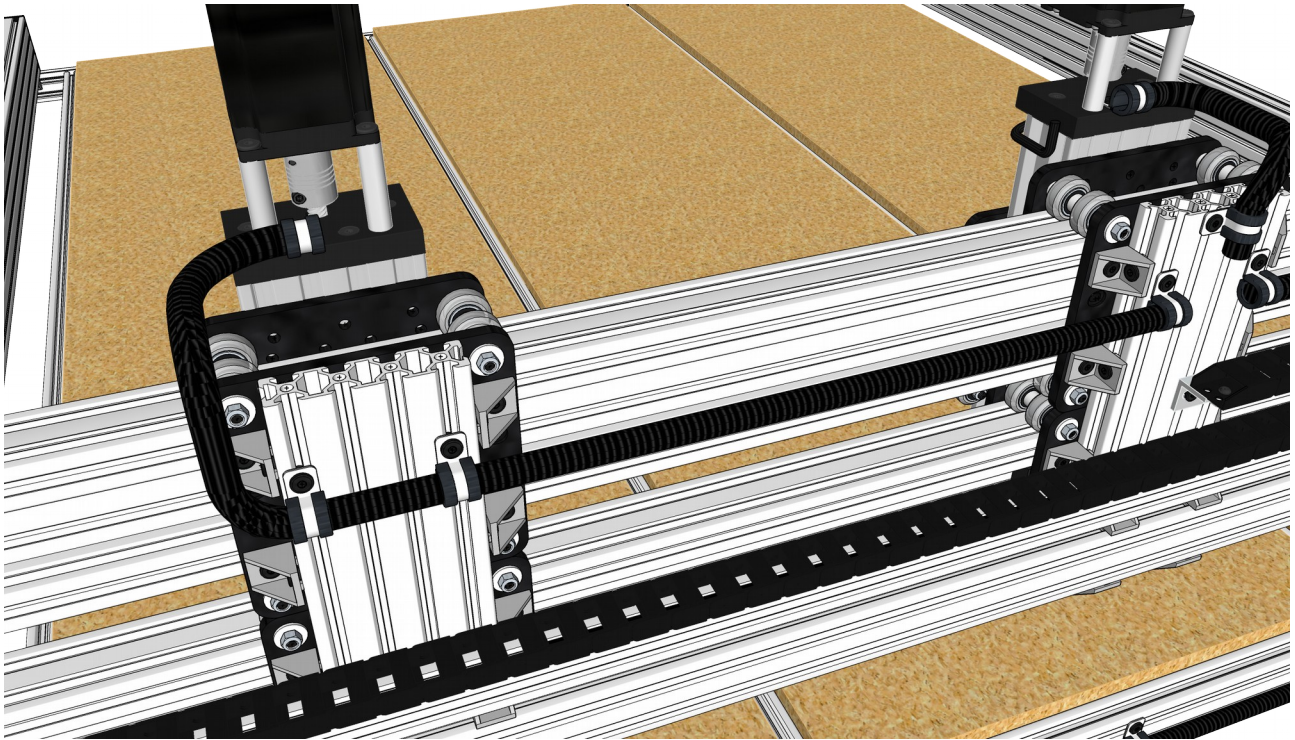

Figure 49: Install Flexible Tubing

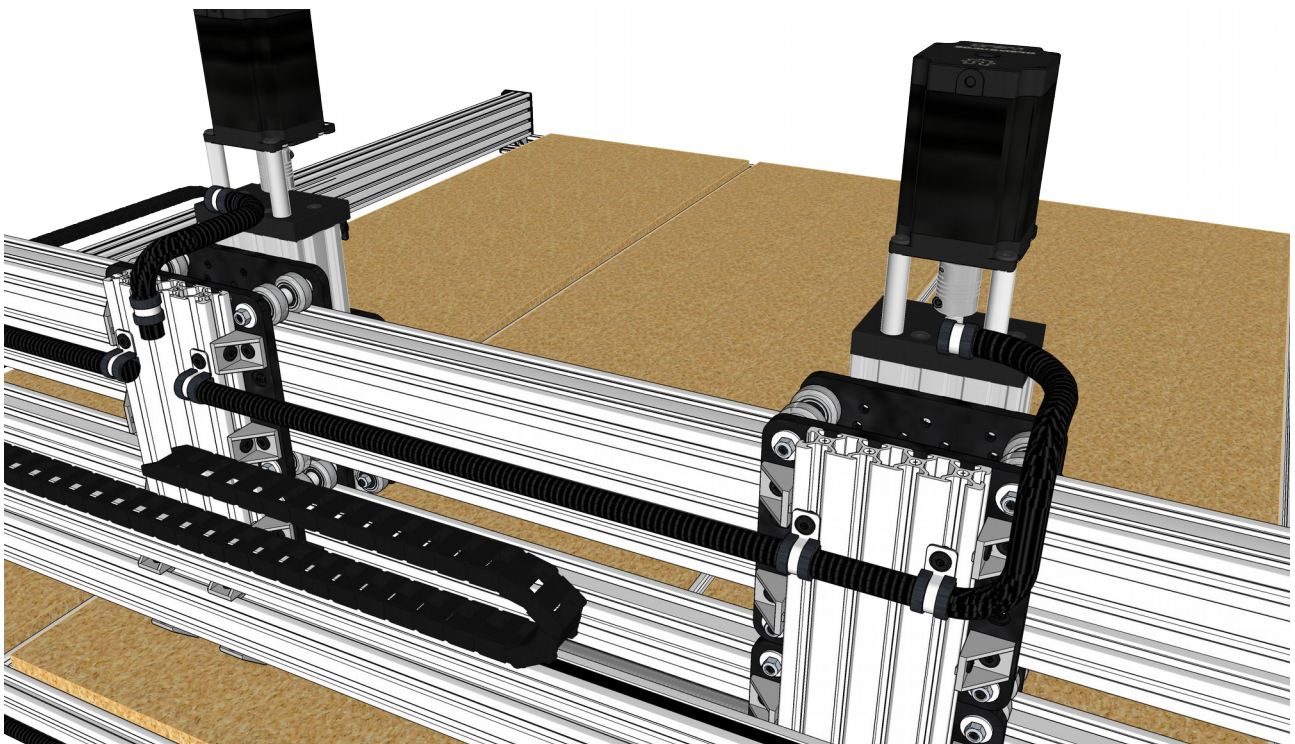

Figure 50: Install Flexible Tubing

6.1.5 Install Terminal Block

Using (2) M3x10mm Button Head Screws and (2) M3 Tee Nuts, install the (1) 4-Way Screw Terminal Block onto the center Z-Axis's Backbone, as shown:

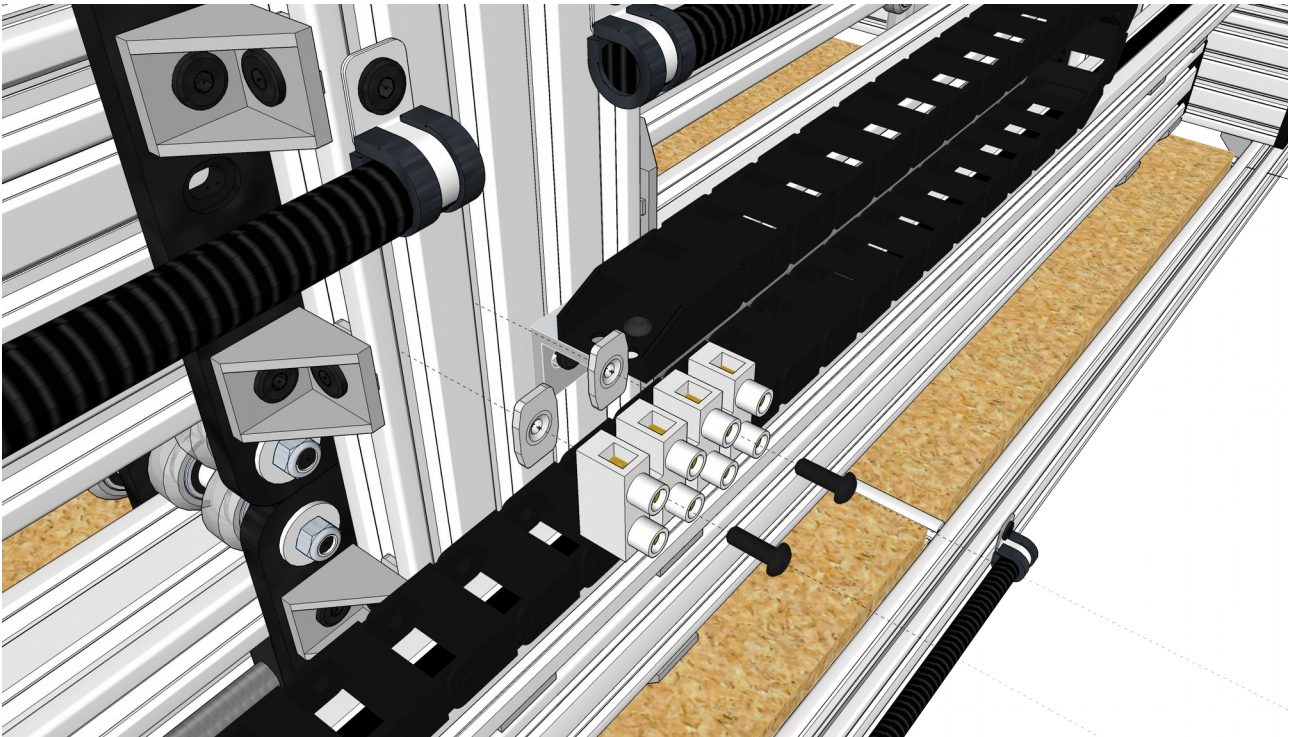

Figure 51: Install 4-Way Screw Terminal Block

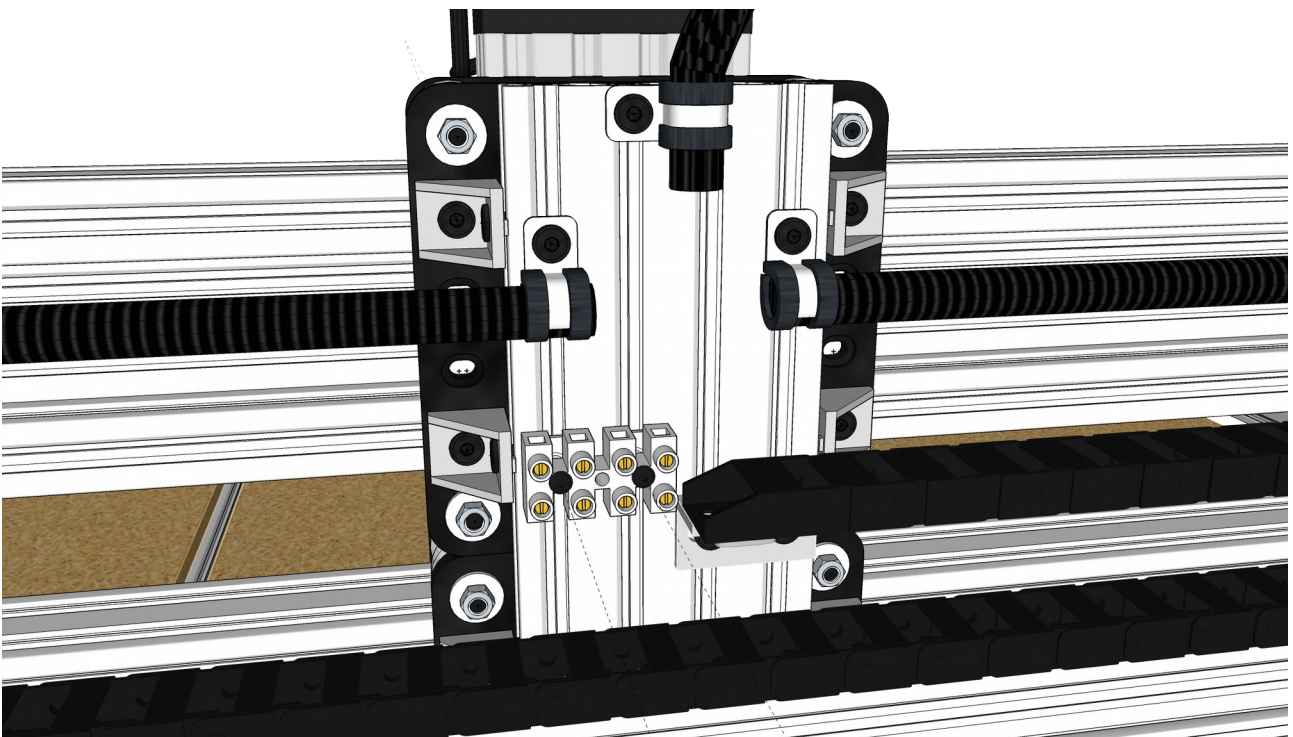

Figure 52: 4-Way Screw Terminal Block Installed

6.1.6 Wire the Terminal Block junction

Take the provided (2) pieces of 3ft long 4-conductor Xtension Wire and run each out from the center to each of the new Z-axis assemblies through the newly installed Flex Tubing. Can be trimmed to length if needed.

Wire all three Z-axis motors in parallel using the 4-Way Terminal Block as shown.

On the other side of the terminal block, join up the 4 wires going back to your controller – following the same color code. Remove the existing Xtensions Connector from this cable to install the wires into the 4-Way Terminal Block as shown.

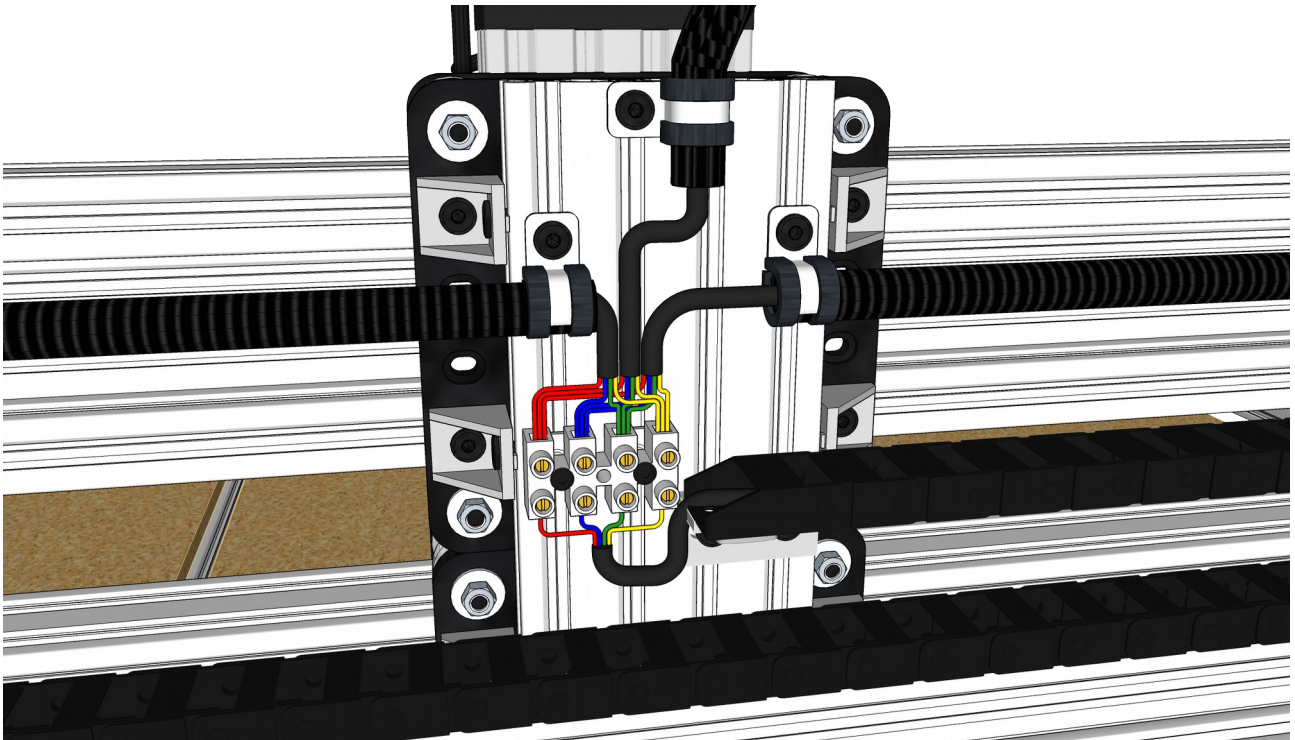

6.1.7 Wire the Stepper Motors

Using (2) 4 Pin Male Xtension Connectors, wire up the other end of the Xtension wires completing the connection of the new Motors on the new Z-Axis Assemblies as shown.

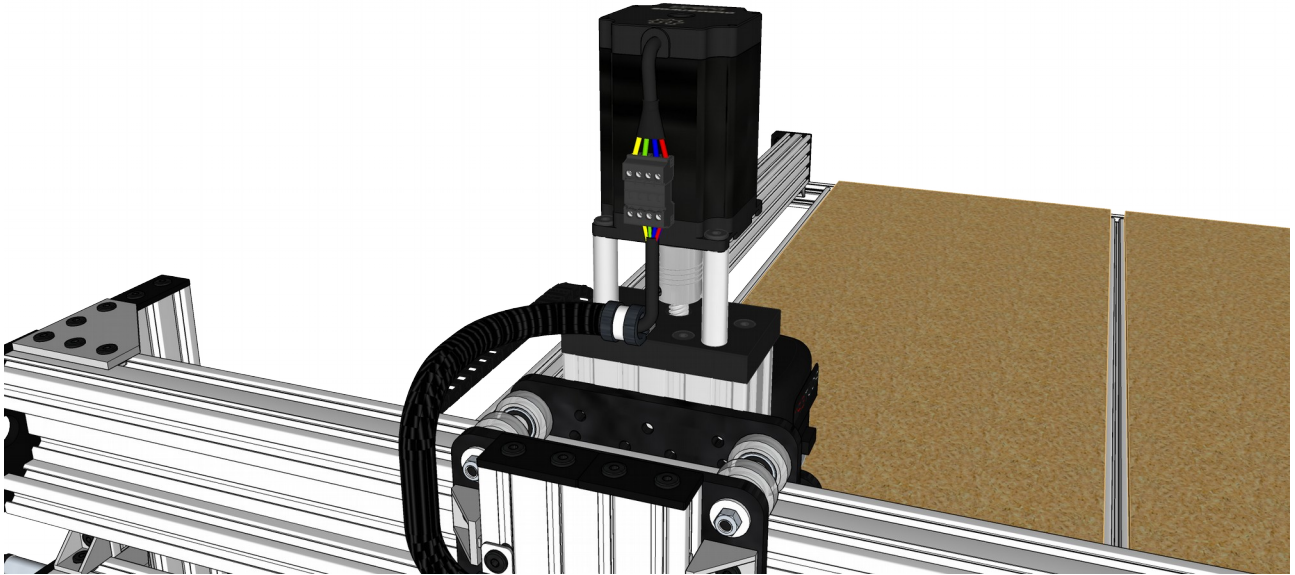

Figure 53: Wiring the stepper motors

6.1.8 Reinstall Endcaps

Install (6) Double End Caps using (12) M5 Self Tapping Screws on top of each of the Z-axis Backbones, as shown

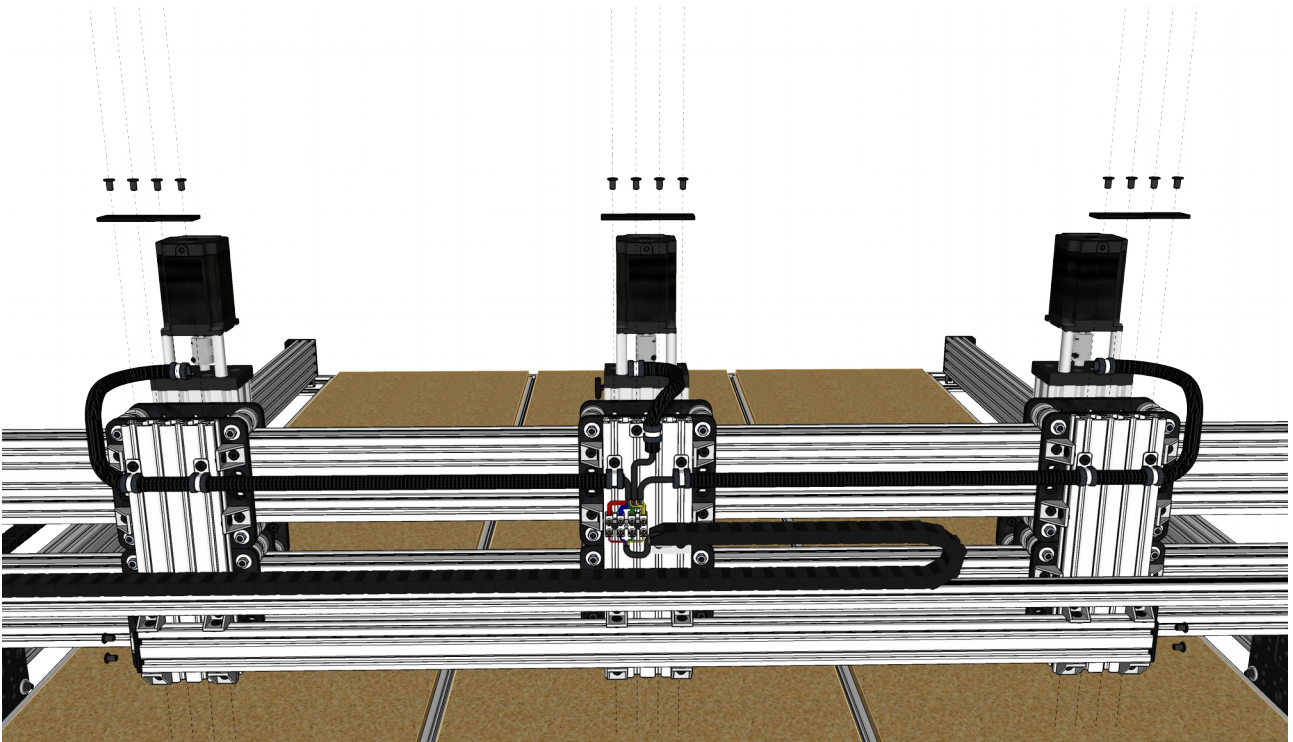

Figure 54: Install Double Endcaps

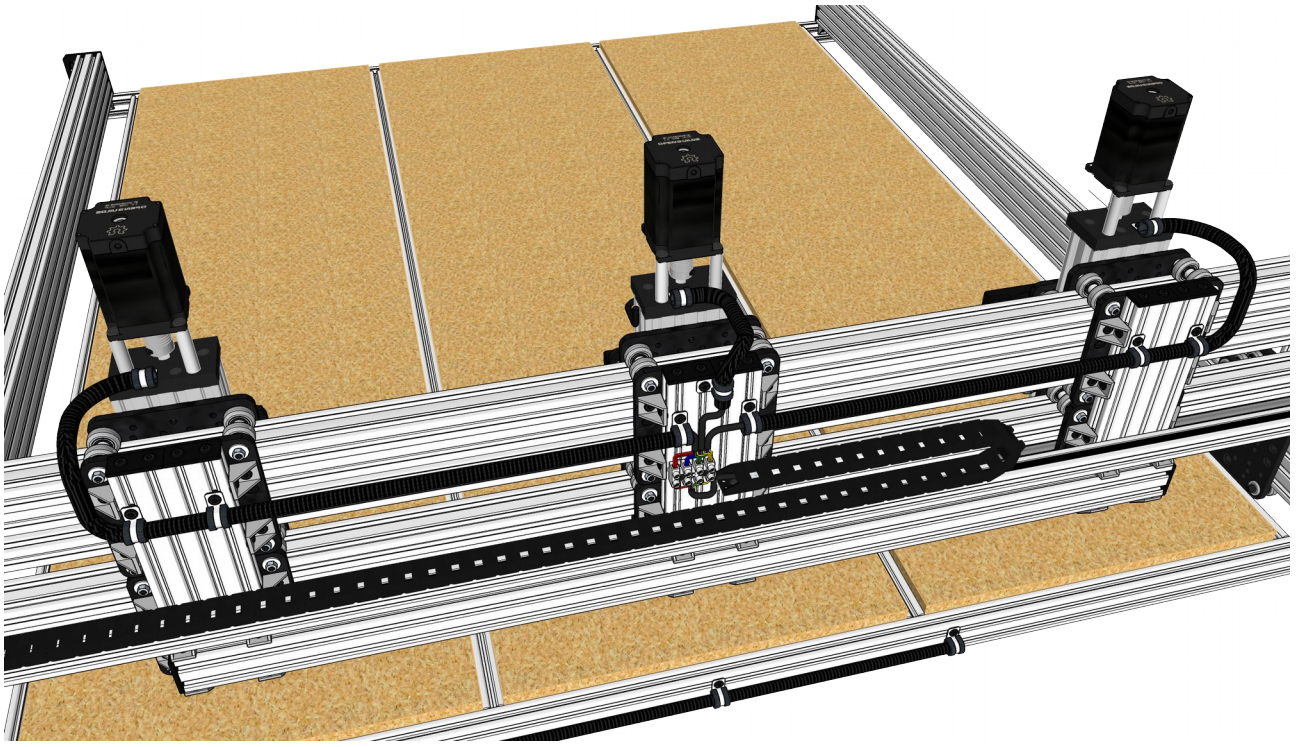
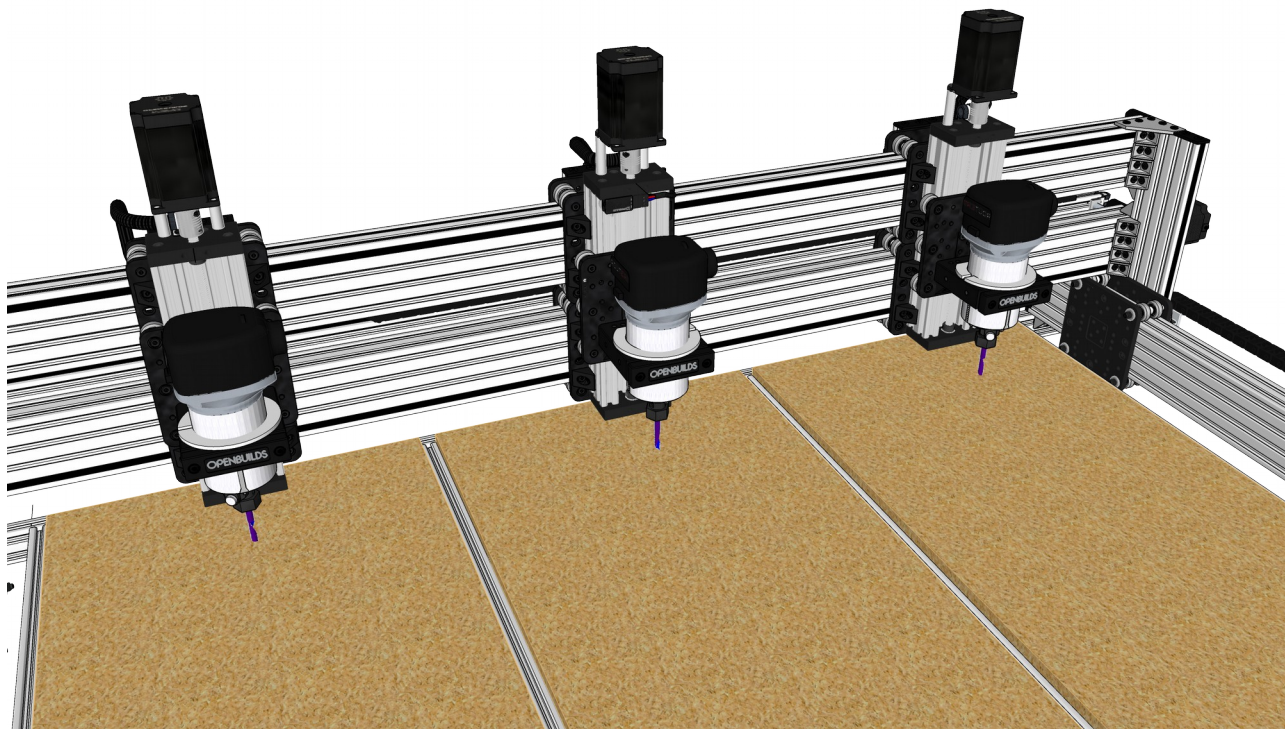

Figure 55: Double End Caps Reinstalled

6.2 Install Routers

Install the (2) additional RoutER11 Routers using the (2) Router Mount Adapters into the Router/Spindle Mounts on the Z axes of the additional Z axes.



If you'd like video guidance on how to install the Routers, see <https://www.youtube.com/watch?v=w3esve017kl>

7. Calibration

7.1 Calibrating Router Height

Use the following procedure to ensure the Z-axes are aligned:

- Ensure the Z axis carriage plates are all level with each other
- Take off all (3) collet nuts from all (3) routers
- Loosen the Router/Spindle Mounts
- Jog the Z Axis to about halfway between up and down with the routers centered in the mounts
- Slowly lower the Z axis until all of router shafts are just resting on the spoiler board
- Tighten all (3) Router/Spindle Mounts locking the routers in place
- Loosely add the collet nuts back on

This has set the bottom edge of each collet housing level with the spoilerboard

7.1 Calibrating Relative Endmill Height

- Jog the Z axes up allowing room for a Bit
- Loosely add the Bits you plan on using (must be loose! Do not tighten Collet Nut yet)
- Slowly jog the Z axis back down to where the bits are all resting on the spoiler board and let them slide into the slightly loose collets. Resting on the spoilboard ensures they all have the same approximate height
- Tighten all collets
- Raise Z-Axis back up
- Add material, Zero bit to the top of the material (jog with setzero or probe) and run your job

8. Assembly Complete!

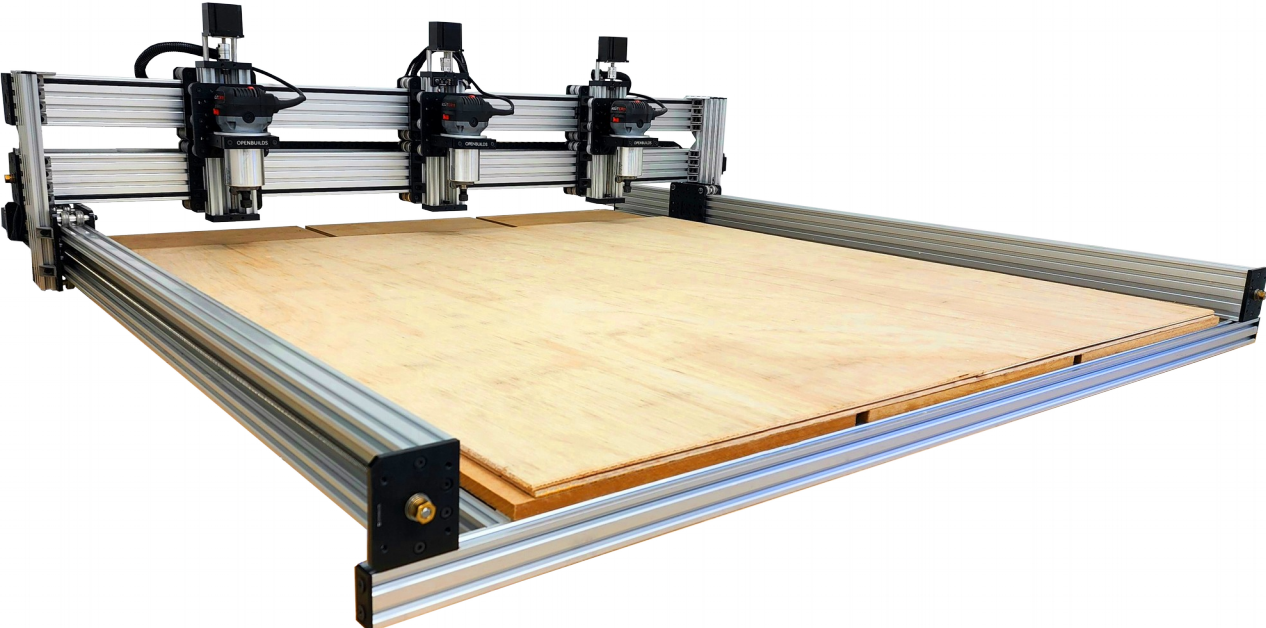

Figure 56: Good job! Let the fun begin!